



CHAOSFAB.COM

# INSTALLATION INSTRUCTIONS

## UNIBALL UPPER CONTROL ARMS

# TC-87504

DATE: 7.1.24  
REV: 03  
SCALE: N.T.S.  
PAGE: 1 OF 4  
DRAWN: CM

### INSTALLATION DRAWINGS ARE FOR THE:

- 2008-2021 LAND CRUISER 200 SERIES
- 2008-2021 LEXUS LX570\*

**\*LEXUS LX570 MODELS EQUIPPED WITH  
FACTORY AUTOMATIC HEIGHT CONTROL  
(AHC) MUST REMOVE SYSTEM PRIOR TO  
INSTALLATION.**

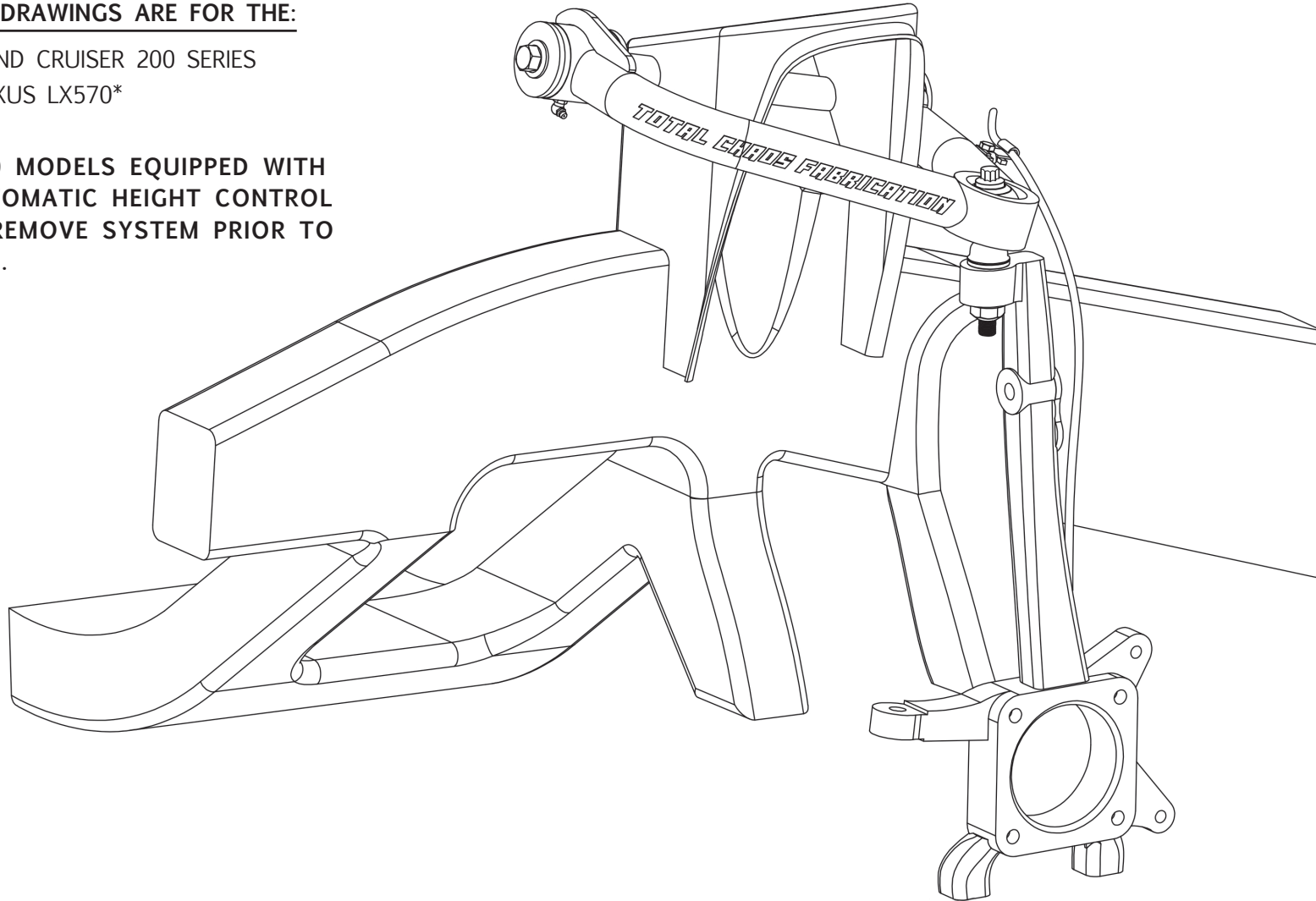

#### PROPRIETARY AND CONFIDENTIAL

THE INFORMATION CONTAINED IN THIS DRAWING IS THE SOLE PROPERTY OF TOTAL CHAOS FABRICATION. ANY REPRODUCTION IN PART OR AS A WHOLE WITHOUT THE WRITTEN PERMISSION OF TOTAL CHAOS FABRICATION IS PROHIBITED.

\*LEFT SIDE OF TRUCK SHOWN. SOME ITEMS NOT SHOWN FOR CLARITY

# INSTALLATION INSTRUCTIONS

## UNIBALL UPPER CONTROL ARMS

**TC-87504**

DATE: 7.1.24  
REV: 03  
SCALE: N.T.S.  
PAGE: 2 OF 4  
DRAWN: CM

ZERK FITTING HOLES ARE TAPPED 1/4"-28.  
IF THE POWDERCOAT BUILDUP IS MAKING  
INSTALLATION DIFFICULT RUN A 1/4"-28  
TAP THROUGH THE HOLE.

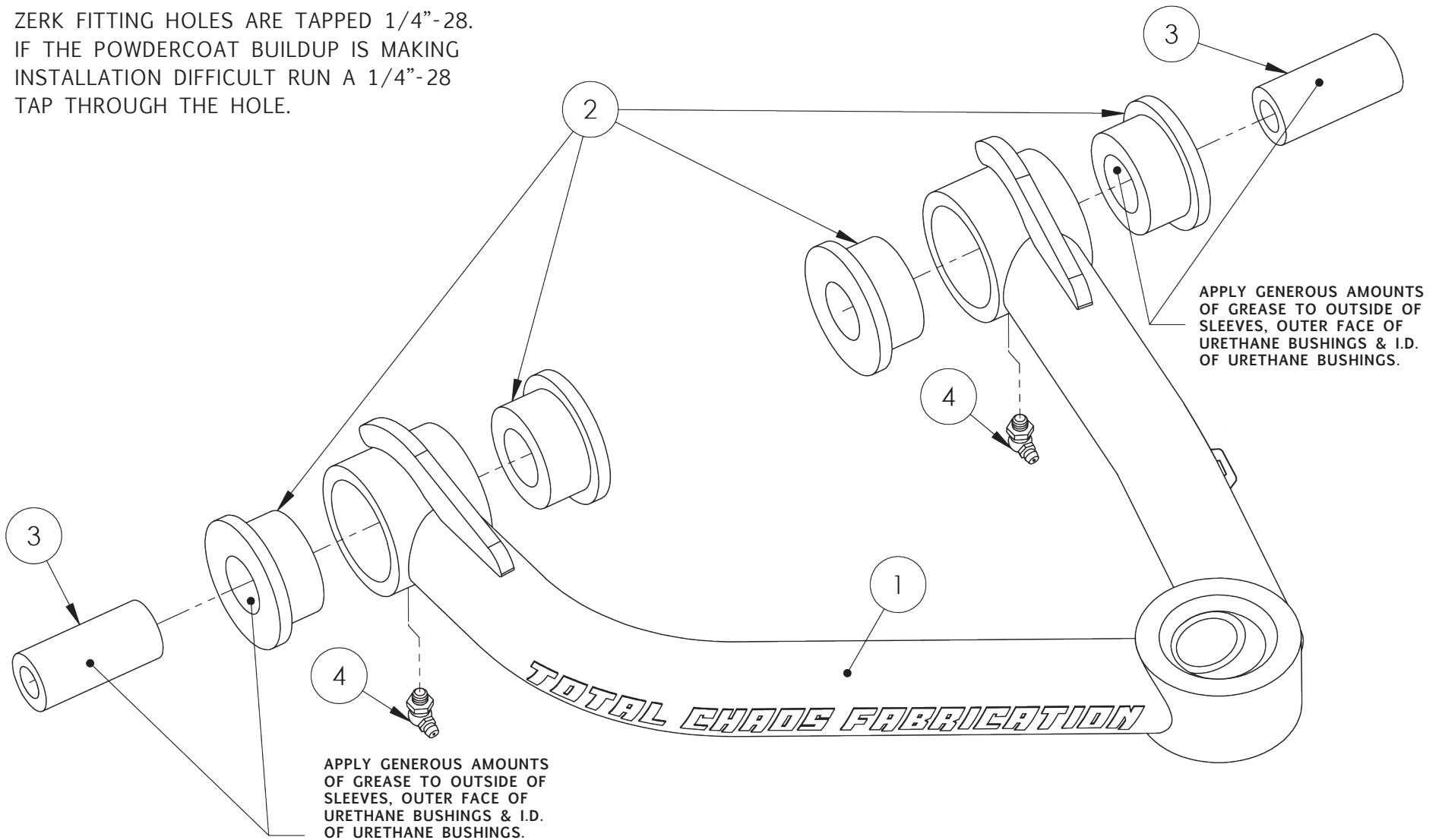

PROPRIETARY AND CONFIDENTIAL

THE INFORMATION CONTAINED IN THIS DRAWING IS THE SOLE PROPERTY OF TOTAL CHAOS FABRICATION. ANY REPRODUCTION IN PART OR AS A WHOLE WITHOUT THE WRITTEN PERMISSION OF TOTAL CHAOS FABRICATION IS PROHIBITED.

\*LEFT SIDE OF TRUCK SHOWN. SOME ITEMS NOT SHOWN FOR CLARITY

# INSTALLATION INSTRUCTIONS

## UNIBALL UPPER CONTROL ARMS

# TC-87504

DATE: 7.1.24  
REV: 03  
SCALE: N.T.S.  
PAGE: 3 OF 4  
DRAWN: CM

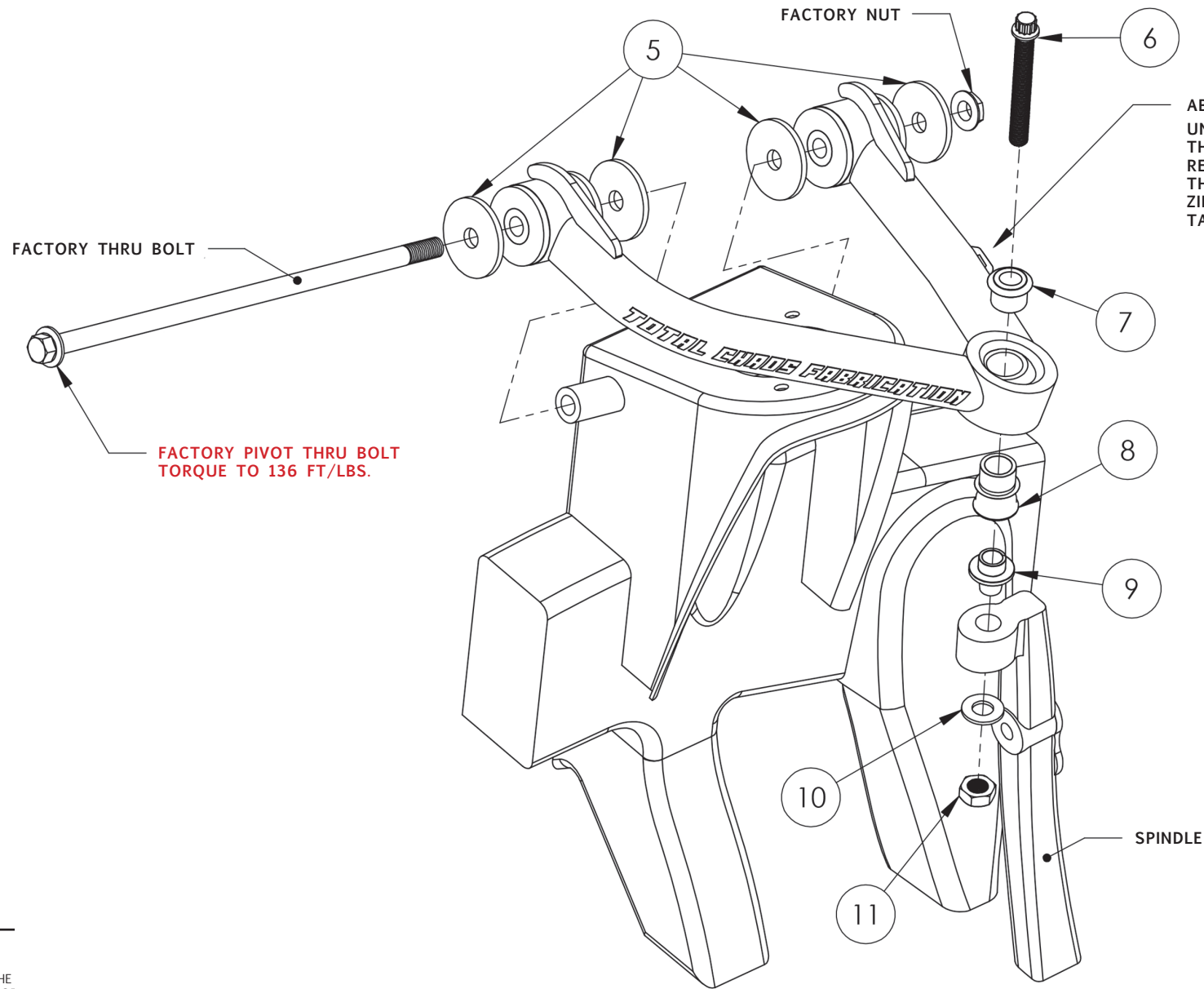

**ABS WIRE MOUNTING INSTRUCTIONS:**  
UNBOLT THE ABS WIRE FROM THE FACTORY CONTROL ARM AND REMOVE THE METAL BRACKET. ONCE THE NEW TC UCA IS INSTALLED, ZIPTIE THE WIRE TO THE PROVIDED TAB.

# INSTALLATION INSTRUCTIONS

## UNIBALL UPPER CONTROL ARMS

# TC-87504

DATE: 7.1.24  
REV: 03  
SCALE: N.T.S.  
PAGE: 4 OF 4  
DRAWN: CM

### INSTALLATION NOTES

- THE FACTORY MANUAL IS REQUIRED FOR TORQUE SPECIFICATIONS ON ALL FACTORY HARDWARE. THIS PROCEDURE WILL INVOLVE THE REMOVAL AND RE-INSTALLATION OF MANY PARTS. ALWAYS USE FACTORY REPLACEMENTS FOR WORN OR DAMAGED PARTS
- SOME ITEMS ARE NOT SHOWN FOR CLARITY
- PAGE 2  
APPLY GENEROUS AMOUNTS OF GREASE TO OUTSIDE OF SLEEVES, OUTER FACE OF URETHANE BUSHINGS & I.D. OF URETHANE BUSHINGS
- PAGE 3  
TORQUE ITEM #6 TO 100 FT/LBS
- INSPECT ALL COMPONENTS AND RE-TORQUE ALL HARDWARE WITHIN 500 MILES

**TOTAL CHAOS FABRICATION**  
159 N. MAPLE ST. UNIT J  
CORONA, CA 92880  
951.737.9682

### PARTS LIST:

ITEM #	PART #	QTY	ITEM DESCRIPTION
1	87504L	1	LEFT UPPER CONTROL ARM
	87504R	1	RIGHT UPPER CONTROL ARM
2	60684	8	BUSHING - URETHANE HALF
3	69707	4	INNER SLEEVE
4	10005	4	FITTING - GREASE (ZERK)
5	69720	8	WASHER - PLATED PIVOT END
6	10242	2	BOLT - 9/16" x 4.00L FLANGE HEAD
7	100916-C	2	SPACER - 9/16" MISALIGNMENT
8	10034-TCF	2	SPACER - 3/4" MISALIGNMENT
9	30005	2	SLEEVE - 9/16" TAPERED ADAPTER
10	12204	2	WASHER - 9/16" SAE
11	11202	2	NUT - 9/16" C-LOCK

#### INSTALL NOTE:

AFTER BOLTING THE CONTROL ARM TO THE FRAME, CYCLE THE ARM TO ENSURE IT DOES NOT CONTACT THE SIDE OF THE COIL BUCKET TOWER. SOME VEHICLES MAY REQUIRE GRINDING THE COIL BUCKET TOWER TO AVOID CONTACT.

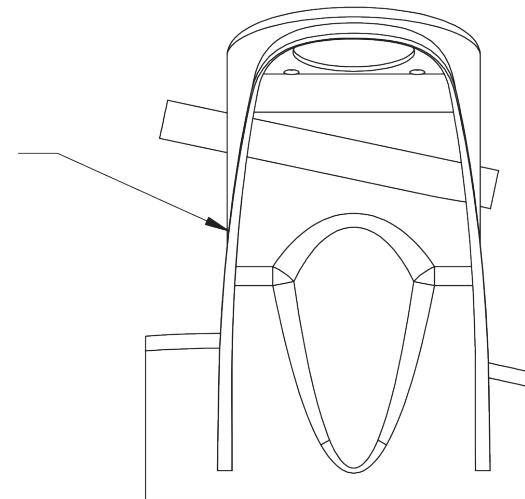

#### PROPRIETARY AND CONFIDENTIAL

THE INFORMATION CONTAINED IN THIS DRAWING IS THE SOLE PROPERTY OF TOTAL CHAOS FABRICATION. ANY REPRODUCTION IN PART OR AS A WHOLE WITHOUT THE WRITTEN PERMISSION OF TOTAL CHAOS FABRICATION IS PROHIBITED.

\*LEFT SIDE OF TRUCK SHOWN. SOME ITEMS NOT SHOWN FOR CLARITY