

INSTALLATION DRAWINGS ARE FOR THE:
2005+ TACOMA PRERUNNER & 4WD
2003+ 4RUNNER 2WD/4WD
2007+ FJ CRUISER

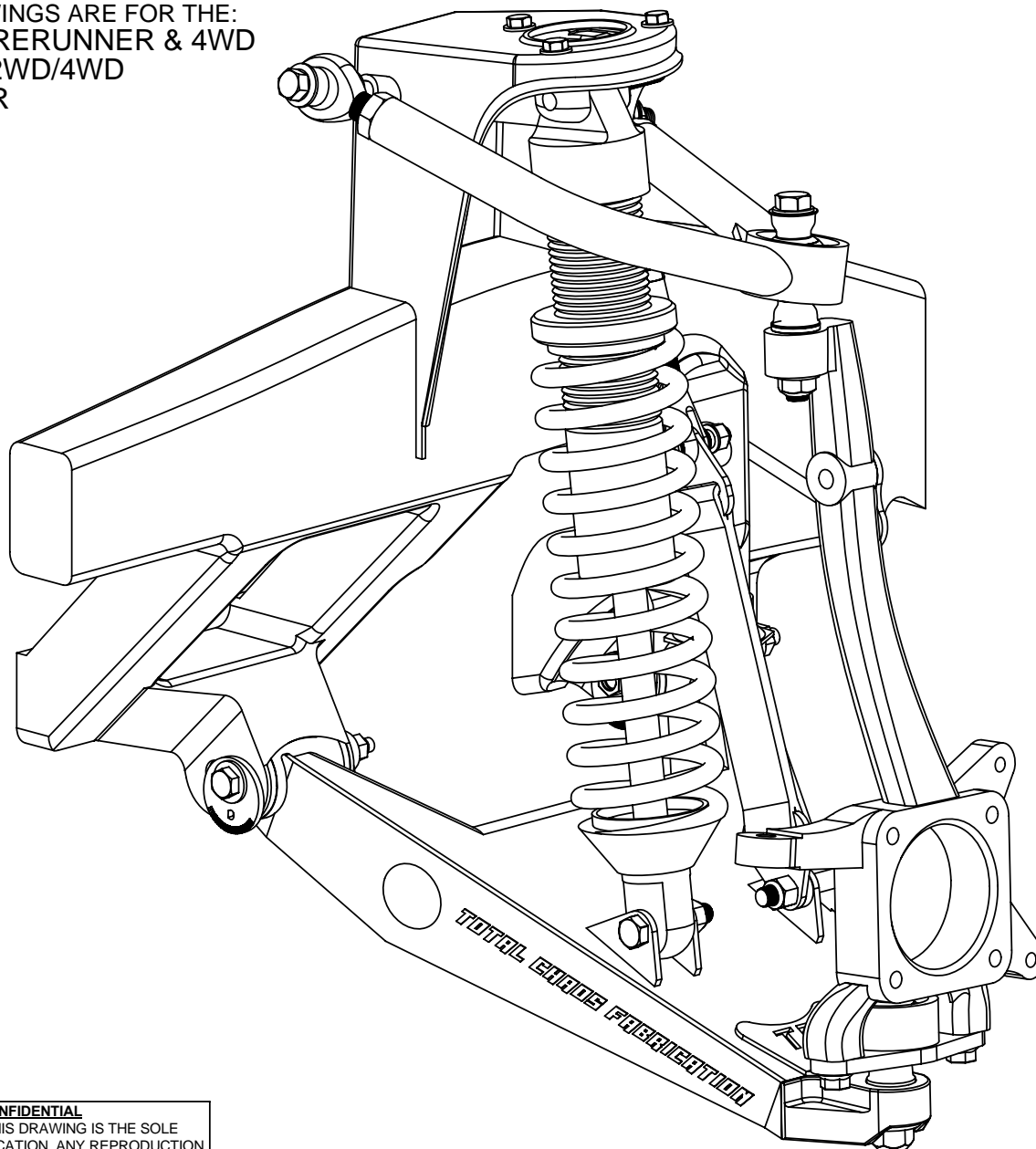

PROPRIETARY AND CONFIDENTIAL

THE INFORMATION CONTAINED IN THIS DRAWING IS THE SOLE PROPERTY OF TOTAL CHAOS FABRICATION. ANY REPRODUCTION IN PART OR AS A WHOLE WITHOUT THE WRITTEN PERMISSION OF TOTAL CHAOS FABRICATION IS PROHIBITED.

*LEFT SIDE OF TRUCK SHOWN. SOME ITEMS NOT SHOWN FOR CLARITY.

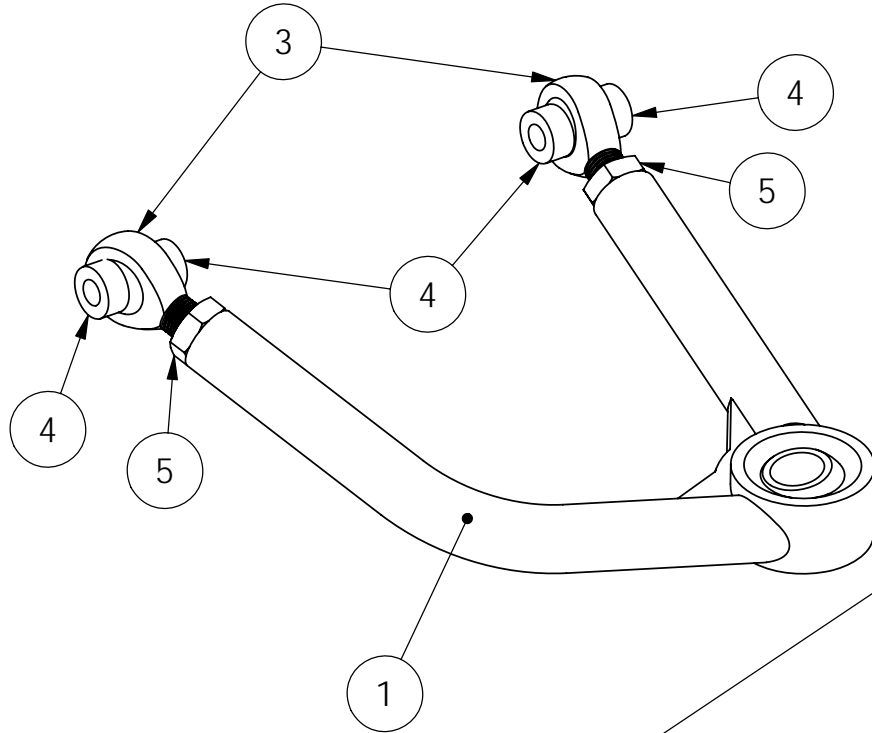

UPPER A-ARM

APPLY GENEROUS
AMOUNTS OF
GREASE TO OUTSIDE
OF SLEEVES AND I.D. OF
URETHANE BUSHINGS

LOWER A-ARM

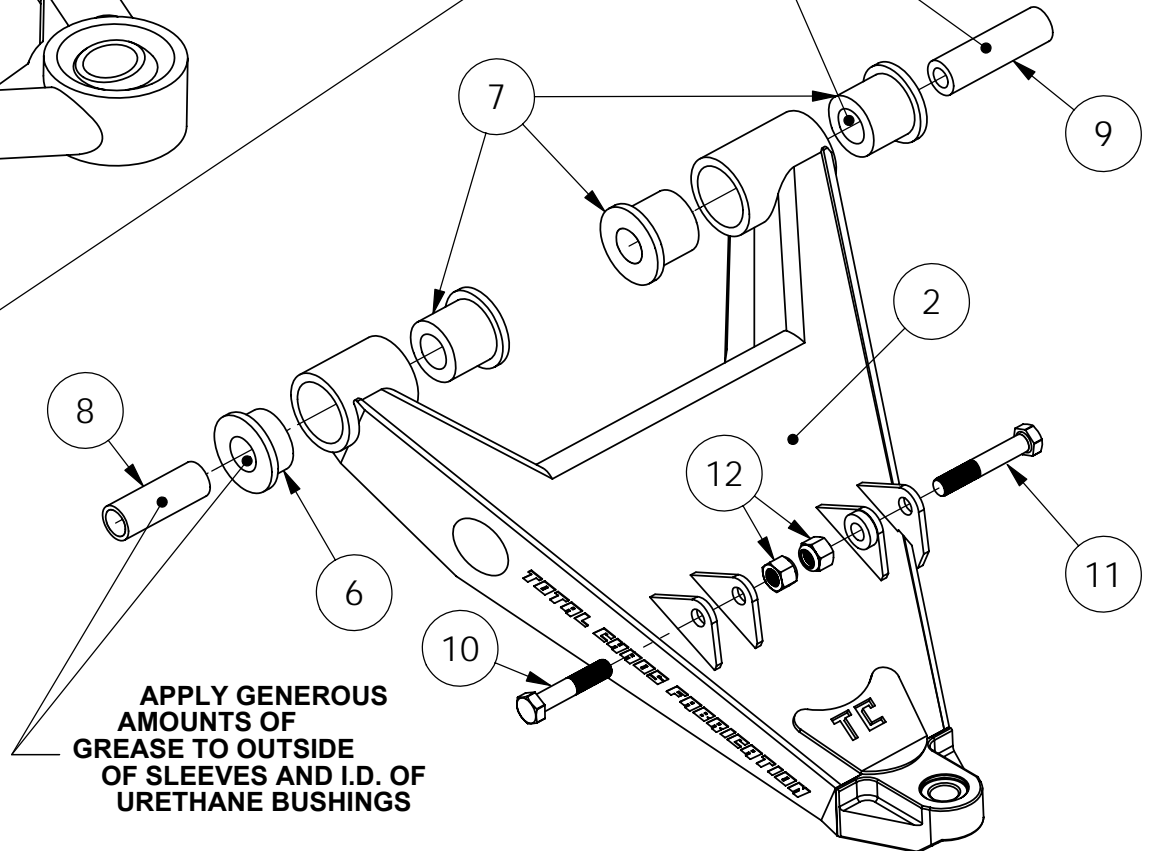

APPLY GENEROUS
AMOUNTS OF
GREASE TO OUTSIDE
OF SLEEVES AND I.D. OF
URETHANE BUSHINGS

PROPRIETARY AND CONFIDENTIAL
THE INFORMATION CONTAINED IN THIS DRAWING IS THE SOLE
PROPERTY OF TOTAL CHAOS FABRICATION. ANY REPRODUCTION
IN PART OR AS A WHOLE WITHOUT THE WRITTEN PERMISSION OF
TOTAL CHAOS FABRICATION IS PROHIBITED.

*LEFT SIDE OF TRUCK SHOWN. SOME ITEMS NOT SHOWN FOR CLARITY.

SHOCK MOUNT

FOR FOX SHOCKS ONLY
WHEN USING KING, SAW & ICON SHOCKS
USE INCLUDED SHOCK MOUNTS

4WD MODELS ONLY

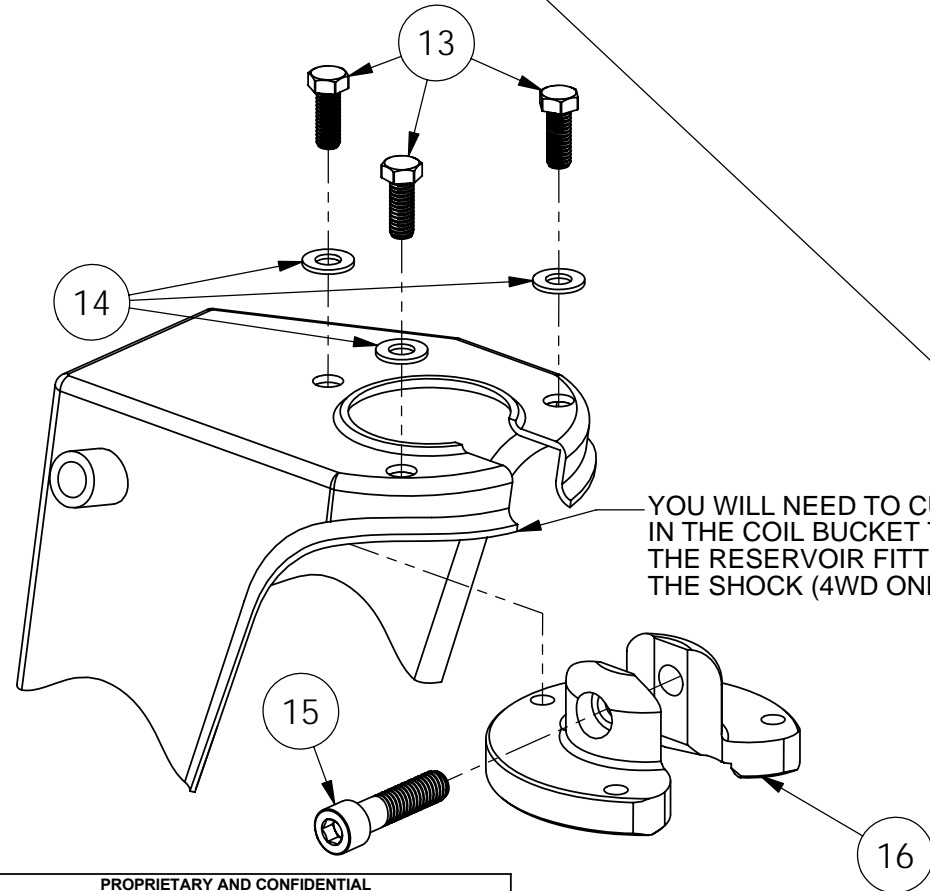

PRERUNNER & 2WD MODELS ONLY

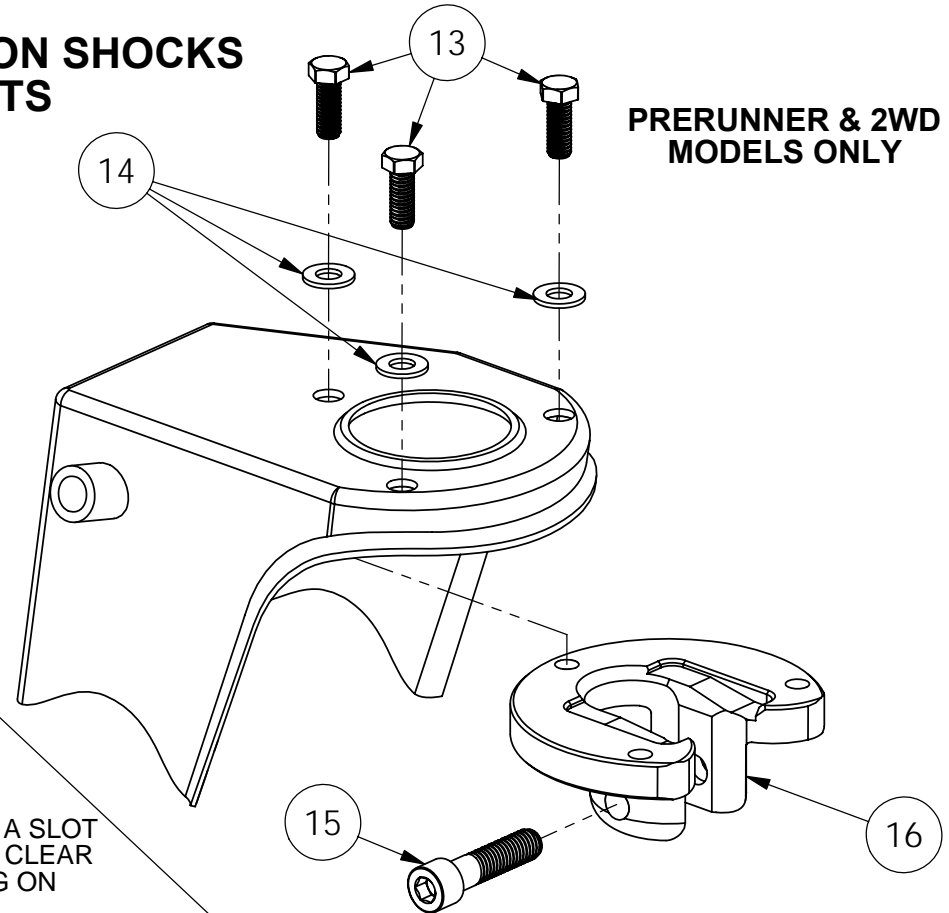

PROPRIETARY AND CONFIDENTIAL
THE INFORMATION CONTAINED IN THIS DRAWING IS THE SOLE PROPERTY OF TOTAL CHAOS FABRICATION. ANY REPRODUCTION IN PART OR AS A WHOLE WITHOUT THE WRITTEN PERMISSION OF TOTAL CHAOS FABRICATION IS PROHIBITED.

*LEFT SIDE OF TRUCK SHOWN. SOME ITEMS NOT SHOWN FOR CLARITY.

**UPPER CONTROL ARM
ATTACHMENT**

**** The heims are assembled and preset to TC specifications. Additional adjustments can be made to modify camber or caster. TC does not recommend that the heim be unthreaded more than 1/4" from its present location.

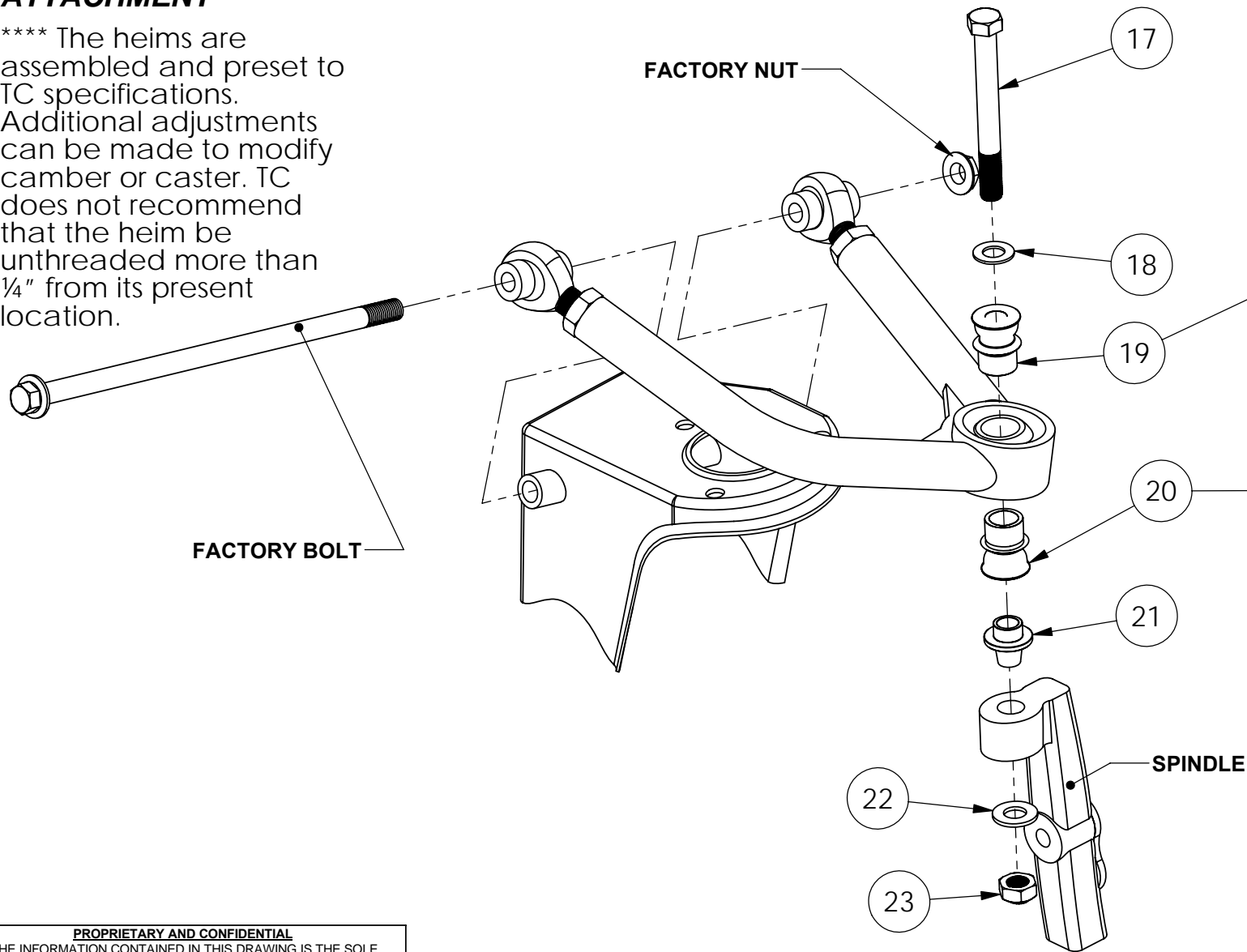

IMPORTANT NOTE:
During assembly, upper & lower spacers are specific. Failure to follow these instructions will result in damage of all components.

Upper spacer has 9/16" hole

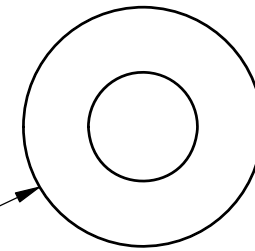

Lower spacer has 3/4" hole

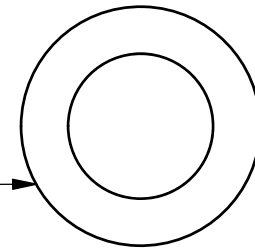

PROPRIETARY AND CONFIDENTIAL
THE INFORMATION CONTAINED IN THIS DRAWING IS THE SOLE PROPERTY OF TOTAL CHAOS FABRICATION. ANY REPRODUCTION IN PART OR AS A WHOLE WITHOUT THE WRITTEN PERMISSION OF TOTAL CHAOS FABRICATION IS PROHIBITED.

*LEFT SIDE OF TRUCK SHOWN. SOME ITEMS NOT SHOWN FOR CLARITY.

UNIBALL CUP MUST BE OFFSET TOWARDS ARM. PERMANENT DAMAGE TO SPINDLE AND UNIBALL ADAPTER MAY OCCUR IF INSTALLED INCORRECTLY.

WELD ITEM #33 AS SHOWN INLINE WITH REAR LOWER A-ARM SHOCK TAB FACE.

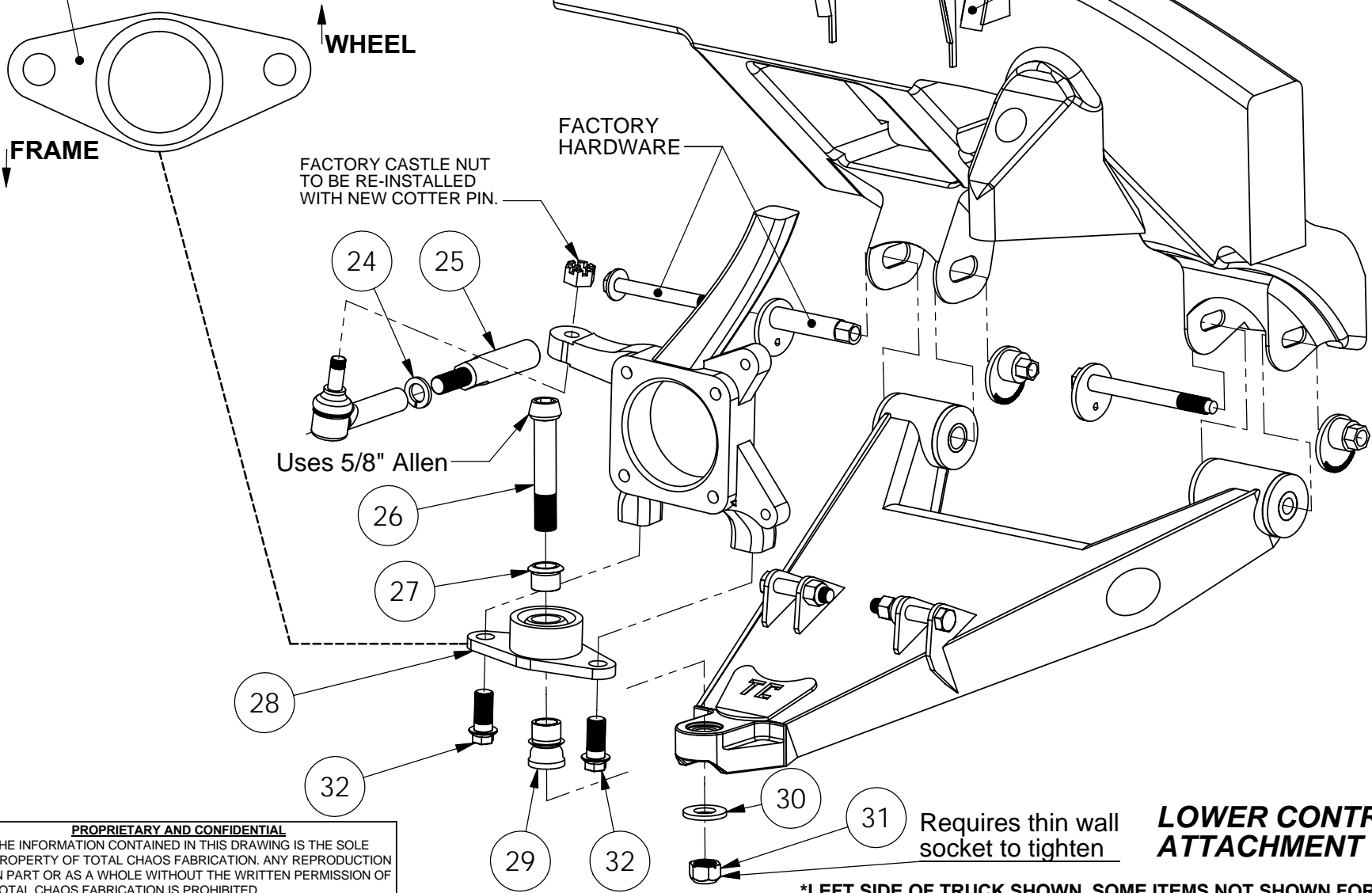

PROPRIETARY AND CONFIDENTIAL
THE INFORMATION CONTAINED IN THIS DRAWING IS THE SOLE PROPERTY OF TOTAL CHAOS FABRICATION. ANY REPRODUCTION IN PART OR AS A WHOLE WITHOUT THE WRITTEN PERMISSION OF TOTAL CHAOS FABRICATION IS PROHIBITED.

LOWER CONTROL ARM ATTACHMENT

*LEFT SIDE OF TRUCK SHOWN. SOME ITEMS NOT SHOWN FOR CLARITY.

BUMP STOP & LIMIT STRAP

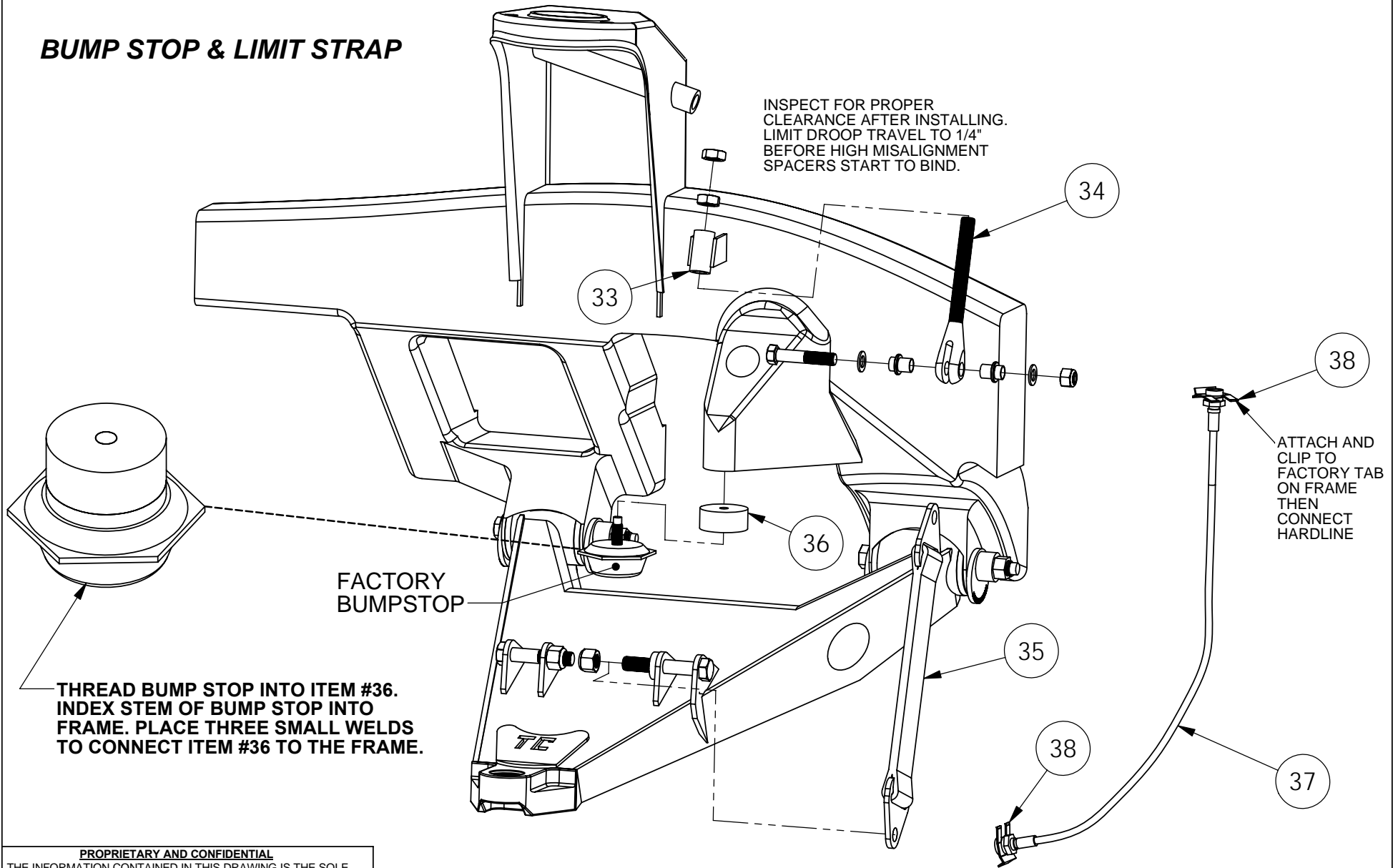

PROPRIETARY AND CONFIDENTIAL

THE INFORMATION CONTAINED IN THIS DRAWING IS THE SOLE PROPERTY OF TOTAL CHAOS FABRICATION. ANY REPRODUCTION IN PART OR AS A WHOLE WITHOUT THE WRITTEN PERMISSION OF TOTAL CHAOS FABRICATION IS PROHIBITED.

*LEFT SIDE OF TRUCK SHOWN. SOME ITEMS NOT SHOWN FOR CLARITY.

INSTALLATION NOTES

The factory manual is required for torque specifications on all hardware. This procedure will involve the removal and re-installation of many parts. Always use factory replacements for worn or damaged parts. Always use new cotter keys during re-installation.

Some items are not shown for clarity.

In order to retain 4 wheel drive, new axles must be purchased from Total Chaos. Please call for more information.

*****IMPORTANT INFORMATION*****

4WD TRUCKS CANNOT BE DRIVEN WITHOUT AXLES INSTALLED!

Page 4
Torque item #17 to 100ft lbs.

Page 5
Torque item #26 to 100ft lbs.

Item #33 - Weld as shown, inline with rear lower a-arm shock tab face. Grind frame to bare metal before proceeding to weld. Placement of brake hardline may need to be adjusted on frame before welding.

Page 6
After installation is complete (shocks installed), adjust limit strap so that there is a 1/4" gap between the high misalignment spacer and the uniball cup on the upper control arm (see model below). Limit straps will stretch over time and will need to be adjusted periodically to prevent damage to shocks and uniball components.

TOTAL CHAOS Fabrication Inc.
159 North Maple St. Unit J
Corona, CA 92880
951.737.9682
WWW.CHAOSFAB.COM

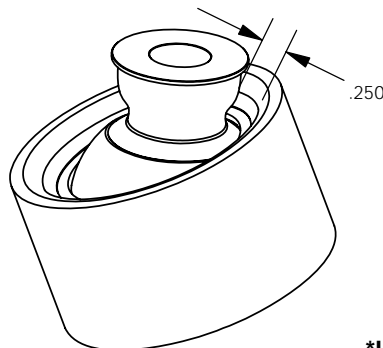

PARTS LIST: 05+ TACOMA/4RUNNER/FJ LONG TRAVEL

ITEM #	PART #	QTY.	ITEM DESCRIPTION
1	68601LH	1	CONTROL ARM, 05 TACO/4RUN/FJ UPPER LEFT
	68601RH	1	CONTROL ARM, 05 TACO/4RUN/FJ UPPER RIGHT
2	68602L	1	CONTROL ARM, 05 TACO/4RUN/FJ LOWER LEFT
	68602R	1	CONTROL ARM, 05 TACO/4RUN/FJ LOWER RIGHT
3	FK-JMX12T	4	HEIM, 3/4" x 3/4" RHT
4	99868	8	SPACER, UPPER CONTROL ARM HEIM
5	11373	4	JAM NUT, 3/4" HEIM
6	60684	2	BUSHING, URETHANE SHORT HALF
7	60292	6	BUSHING, URETHANE LONG HALF
8	69702	2	SLEEVE, LOWER ARM FRONT INNER
9	68603	2	SLEEVE, LOWER ARM REAR INNER
10	10025	2	BOLT, 1/2" x 2.50L FRONT SHOCK
11	10030	2	BOLT, 1/2" x 3.00L REAR SHOCK
12	11001	4	NUT, 1/2" NYLOCK
13	10710	6	BOLT, 3/8" X 1.00L SHOCK MOUNT
14	12011	6	WASHER, 3/8" SAE SHOCK MOUNT
15	10020	2	BOLT, 1/2" SOCKET HEAD FOX/KING SHOCK
	10025	2	BOLT, 1/2" x 2.50L SWAY A WAY SHOCK
16	58621K	2	SHOCK CIRCLE, BILLET, FOX/KING
17	10251	2	BOLT, 9/16" x 5.00L
18	12203	2	WASHER, 9/16" AN
19	100916TCF	2	SPACER, TOP UPPER ARM MISALIGNMENT
20	10034TCF	2	SPACER, BOTTOM UPPER ARM MISALIGNMENT
21	30004	2	SLEEVE, 9/16" TAPERED ADAPTER
22	12204	2	WASHER, 9/16" SAE
23	11202	2	NUT, 9/16" C-LOCK
24	12016	2	WASHER, 16MM LOCK, TACOMA
	12015	2	WASHER, 15MM LOCK, 4RUNNER & FJ
25	99016	2	EXTENSION, 16MM TIEROD, TACOMA
	99015	2	EXTENSION, 15MM TIEROD, 4RUNNER & FJ
26	10342	2	BOLT, 3/4" x 4.25L SOCKET HEAD
27	10034C	2	SPACER, TOP LOWER ARM MISALIGNMENT
28	68614	2	ADAPTER, LOWER UNIBALL 2-BOLT FLANGE
29	10034T	2	SPACER, BOTTOM LOWER ARM MISALIGNMENT
30	12304	2	WASHER, 3/4" SAE
31	11302	2	NUT, 3/4" GRADE C LOCK
32	10616	4	BOLT, 16MM X 45MM FLANGE HEAD
33	69619	2	BRACKET, LIMIT STRAP CLEVIS, WELD ON
34	69618	2	CLEVIS, ADJUSTABLE LIMIT STRAP
35	69617	2	STRAP, 12" LIMIT
36	68610	2	SPACER, BUMPSTOP
37	97330	2	LINE, EXTENDED BRAKE
38	33301	4	CLIP, BRAKELINE RETAINING

PROPRIETARY AND CONFIDENTIAL
THE INFORMATION CONTAINED IN THIS DRAWING IS THE SOLE PROPERTY OF TOTAL CHAOS FABRICATION. ANY REPRODUCTION IN PART OR AS A WHOLE WITHOUT THE WRITTEN PERMISSION OF TOTAL CHAOS FABRICATION IS PROHIBITED.