

INSTALLATION DRAWINGS ARE FOR THE:
2004+ TITAN 2WD/4WD
2004+ ARMADA 2WD/4WD

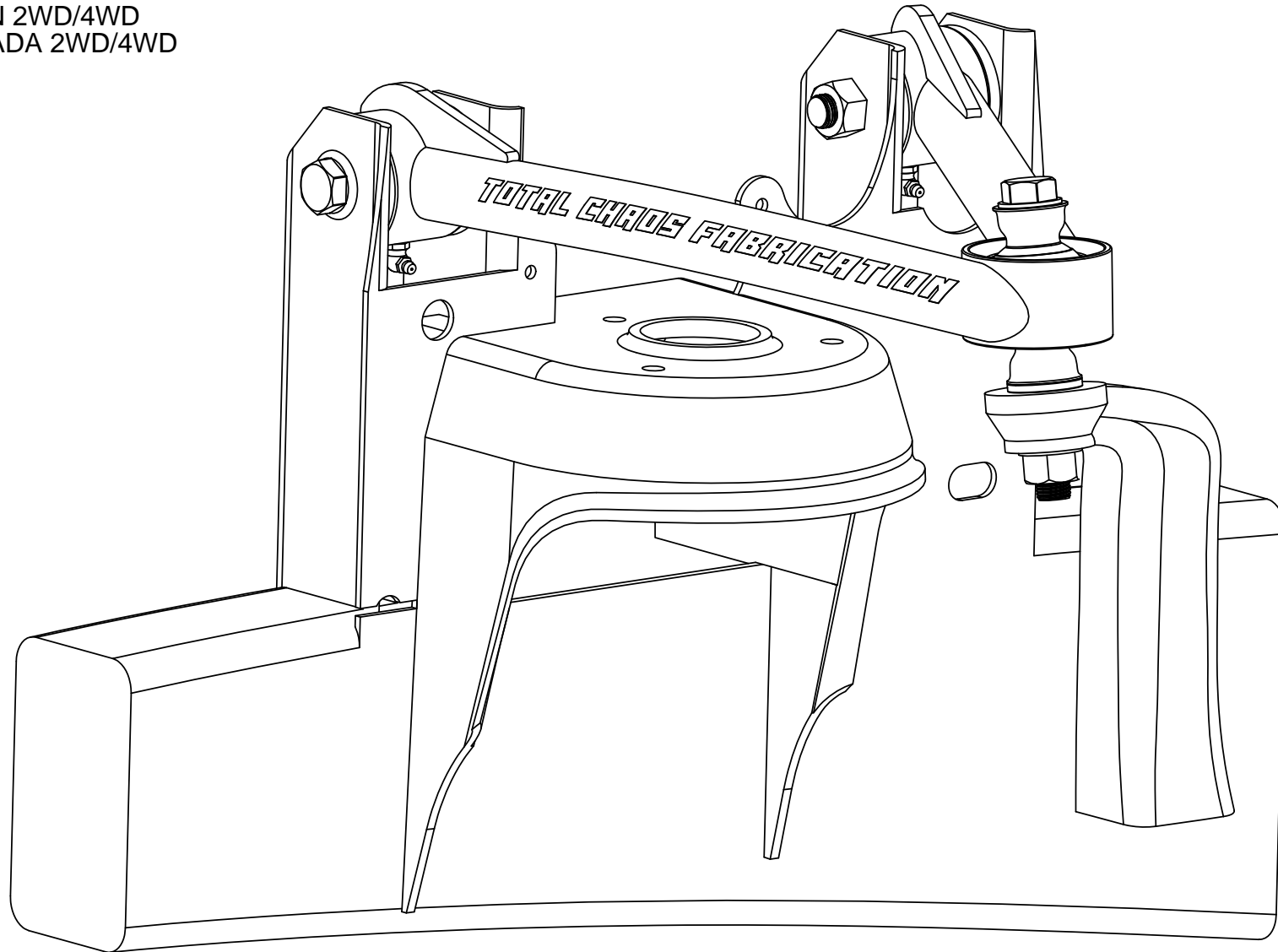

PROPRIETARY AND CONFIDENTIAL

THE INFORMATION CONTAINED IN THIS DRAWING IS THE SOLE PROPERTY OF TOTAL CHAOS FABRICATION. ANY REPRODUCTION IN PART OR AS A WHOLE WITHOUT THE WRITTEN PERMISSION OF TOTAL CHAOS FABRICATION IS PROHIBITED.

*LEFT SIDE OF TRUCK SHOWN. SOME ITEMS NOT SHOWN FOR CLARITY.

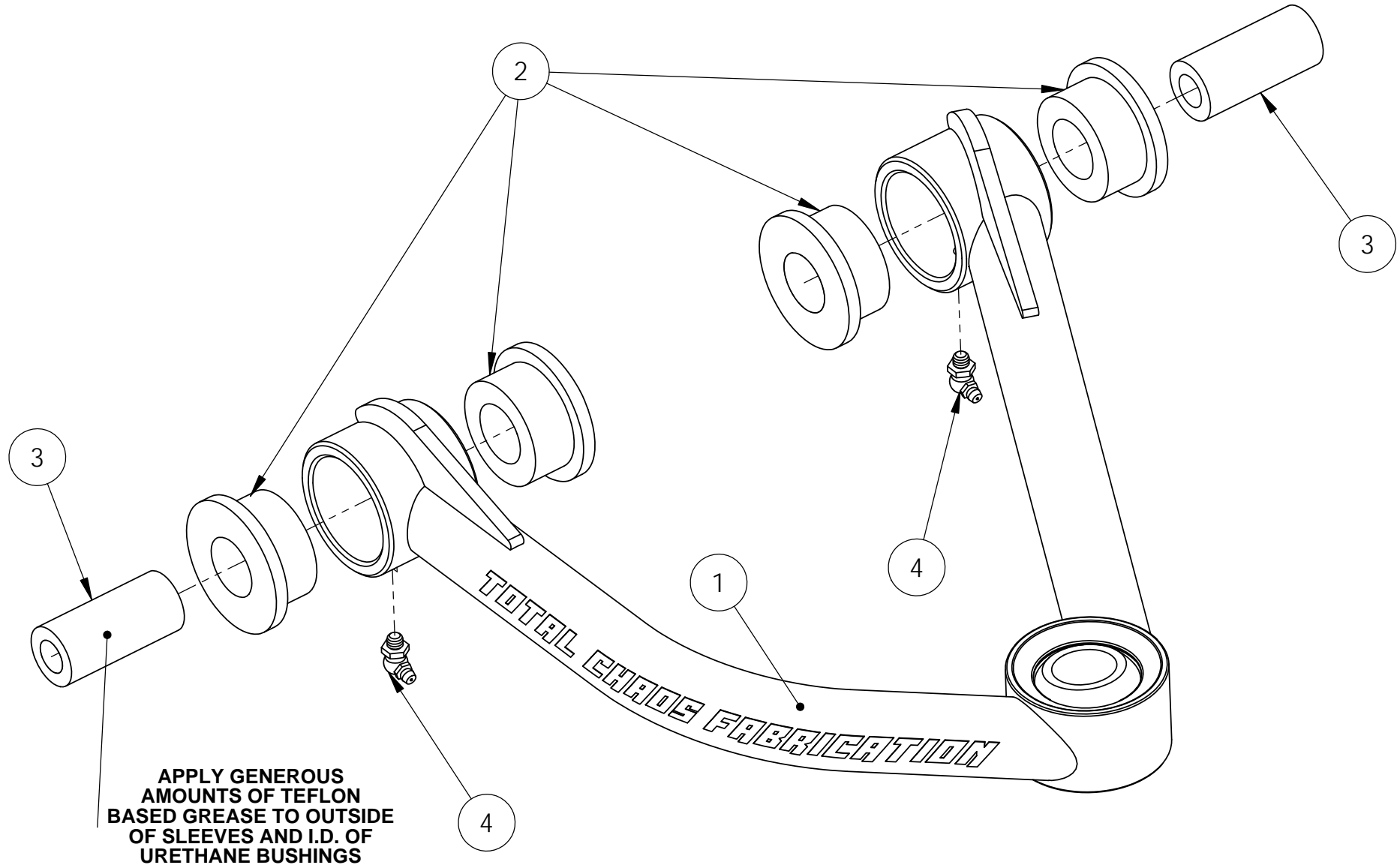

**APPLY GENEROUS
AMOUNTS OF TEFLON
BASED GREASE TO OUTSIDE
OF SLEEVES AND I.D. OF
URETHANE BUSHINGS**

PROPRIETARY AND CONFIDENTIAL

THE INFORMATION CONTAINED IN THIS DRAWING IS THE SOLE PROPERTY OF TOTAL CHAOS FABRICATION. ANY REPRODUCTION IN PART OR AS A WHOLE WITHOUT THE WRITTEN PERMISSION OF TOTAL CHAOS FABRICATION IS PROHIBITED.

*LEFT SIDE OF TRUCK SHOWN. SOME ITEMS NOT SHOWN FOR CLARITY.

Important Note:

Once the factory upper control arm is removed, there are two raised contact points in each pivot on the frame. These must be ground or sanded down to allow the TC control arm to fit properly.

FACTORY BOLT

FACTORY NUT

You may have to grind the hat of the bushings to fit/clearance into the factory pocket.

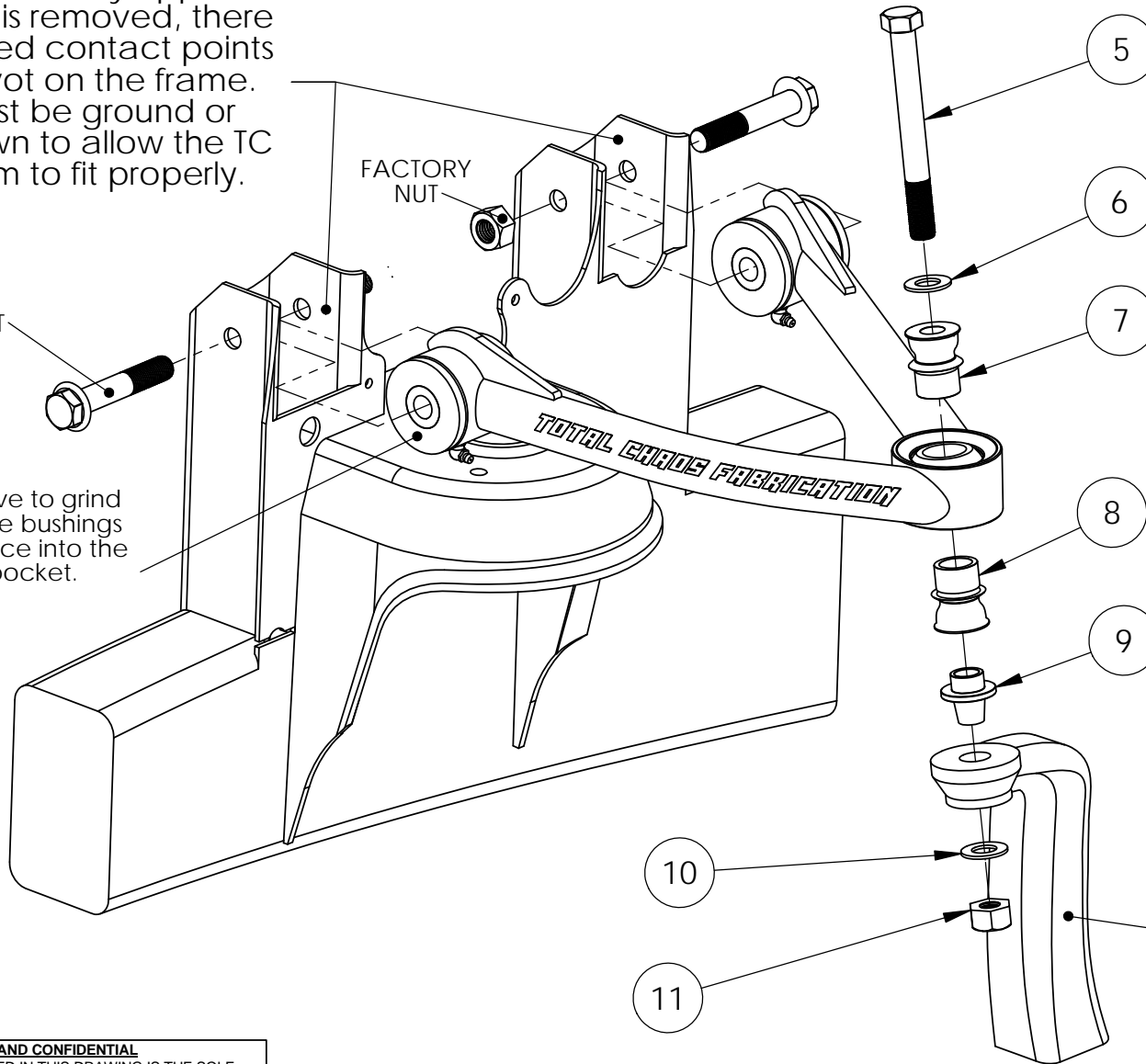

IMPORTANT NOTE:
During assembly, upper & lower spacers are specific. Failure to follow these instructions will result in damage of all components.

Upper spacer has 9/16" hole

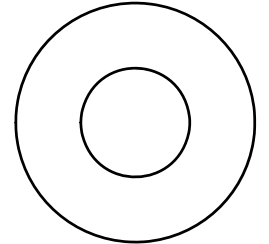

Lower spacer has 3/4" hole

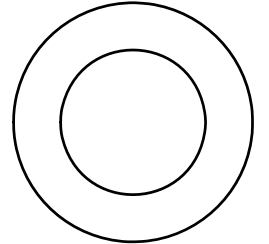

PROPRIETARY AND CONFIDENTIAL
THE INFORMATION CONTAINED IN THIS DRAWING IS THE SOLE PROPERTY OF TOTAL CHAOS FABRICATION. ANY REPRODUCTION IN PART OR AS A WHOLE WITHOUT THE WRITTEN PERMISSION OF TOTAL CHAOS FABRICATION IS PROHIBITED.

*LEFT SIDE OF TRUCK SHOWN. SOME ITEMS NOT SHOWN FOR CLARITY.

INSTALLATION NOTES

The factory manual is required for torque specifications on all factory hardware. This procedure will involve the removal and re-installation of many parts. Always use factory replacements for worn or damaged parts. Always use new cotter keys during re-installation.

Some items are not shown for clarity.

Page 2
Apply generous amounts of teflon based grease to outside of sleeves and I.D. of urethane bushings. (Teflon based grease is available from TOTAL CHAOS. Part # - Superlube)

Page 3
Torque Item# 5 to 90-100 ft/lbs.
All noted procedures must be performed on this page to ensure complete installation.

Inspect all components and re-torque all hardware within 500 miles.

PARTS LIST: 04+ TITAN UPPER CONTROL ARM			
ITEM #	PART #	QTY.	ITEM DESCRIPTION
1	99051L	1	CONTROL ARM, 04+ TITAN UPPER LEFT
	99051R	1	CONTROL ARM, 04+ TITAN UPPER RIGHT
2	60684	8	BUSHING, URETHANE HALF
3	69120	4	INNER SLEEVE
4	10005	4	FITTING, GREASE (ZERK)
5	10251	2	BOLT, 9/16" x 5.00L
6	12203	2	WASHER, 9/16" AN
7	100916	2	SPACER, 9/16" MISALIGNMENT
8	10034TCF	2	SPACER, 3/4" MISALIGNMENT
9	30004	2	SLEEVE, 9/16" TAPERED ADAPTER
10	12204	2	WASHER, 9/16" SAE
11	11202	2	NUT, 9/16" C-LOCK

TOTAL CHAOS Fabrication Inc.
159 North Maple St. Unit J
Corona, CA 92880
951.737.9682

PROPRIETARY AND CONFIDENTIAL
THE INFORMATION CONTAINED IN THIS DRAWING IS THE SOLE PROPERTY OF TOTAL CHAOS FABRICATION. ANY REPRODUCTION IN PART OR AS A WHOLE WITHOUT THE WRITTEN PERMISSION OF TOTAL CHAOS FABRICATION IS PROHIBITED.

*LEFT SIDE OF TRUCK SHOWN. SOME ITEMS NOT SHOWN FOR CLARITY.