

INSTALLATION DRAWINGS FOR THE:
1995.5-2004 TACOMA PRERUNNER & 4WD (96500)
1996-2002 4RUNNER 2WD/4WD (96500)

2000-2006 TUNDRA 2WD/4WD (97500)
2001-2007 SEQUOIA 2WD/4WD (97500)

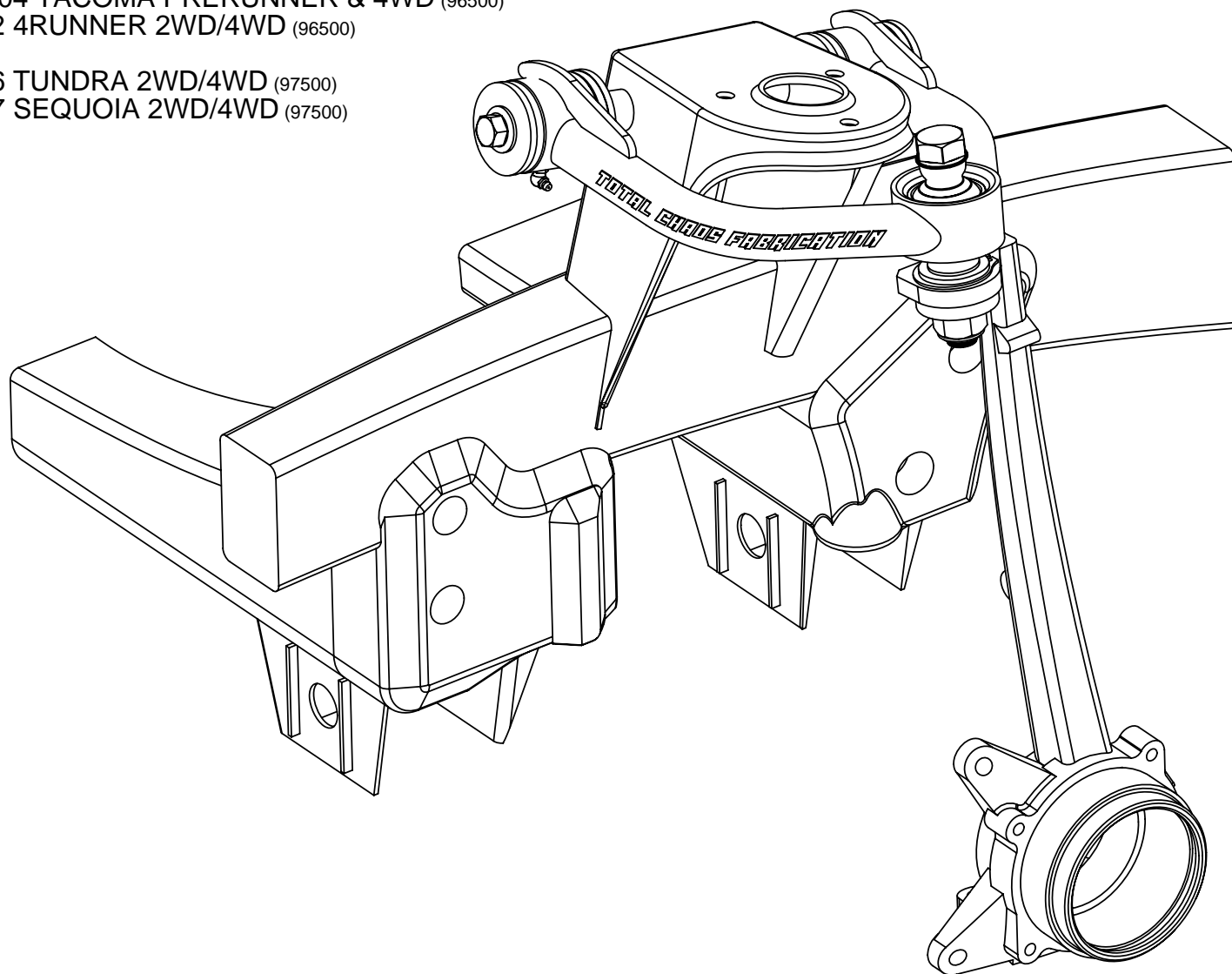

PROPRIETARY AND CONFIDENTIAL

THE INFORMATION CONTAINED IN THIS DRAWING IS THE SOLE PROPERTY OF TOTAL CHAOS FABRICATION. ANY REPRODUCTION IN PART OR AS A WHOLE WITHOUT THE WRITTEN PERMISSION OF TOTAL CHAOS FABRICATION IS PROHIBITED.

*LEFT SIDE OF TRUCK SHOWN. SOME ITEMS NOT SHOWN FOR CLARITY.

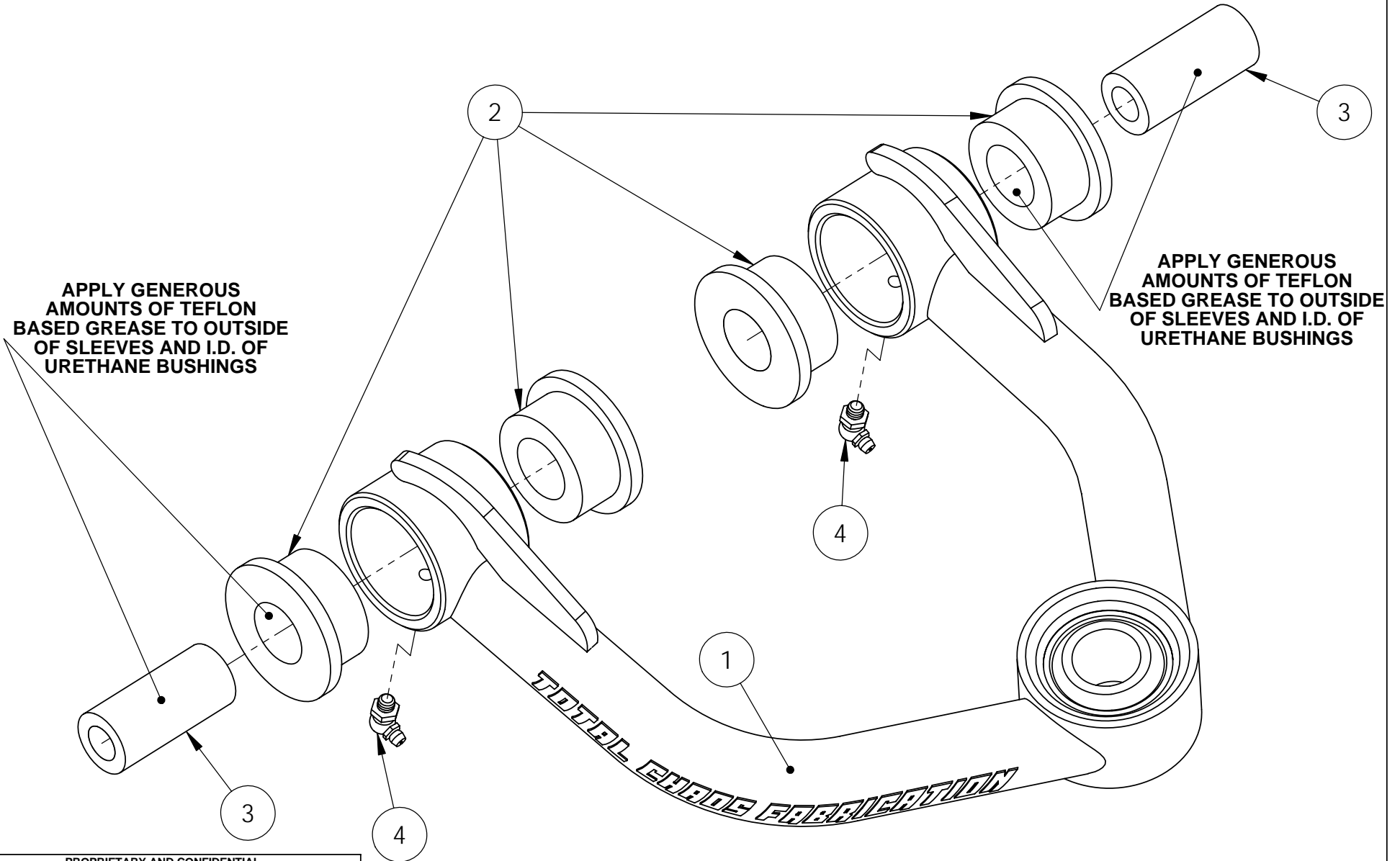

PROPRIETARY AND CONFIDENTIAL
THE INFORMATION CONTAINED IN THIS DRAWING IS THE SOLE PROPERTY OF TOTAL CHAOS FABRICATION. ANY REPRODUCTION IN PART OR AS A WHOLE WITHOUT THE WRITTEN PERMISSION OF TOTAL CHAOS FABRICATION IS PROHIBITED.

*LEFT SIDE OF TRUCK SHOWN. SOME ITEMS NOT SHOWN FOR CLARITY.

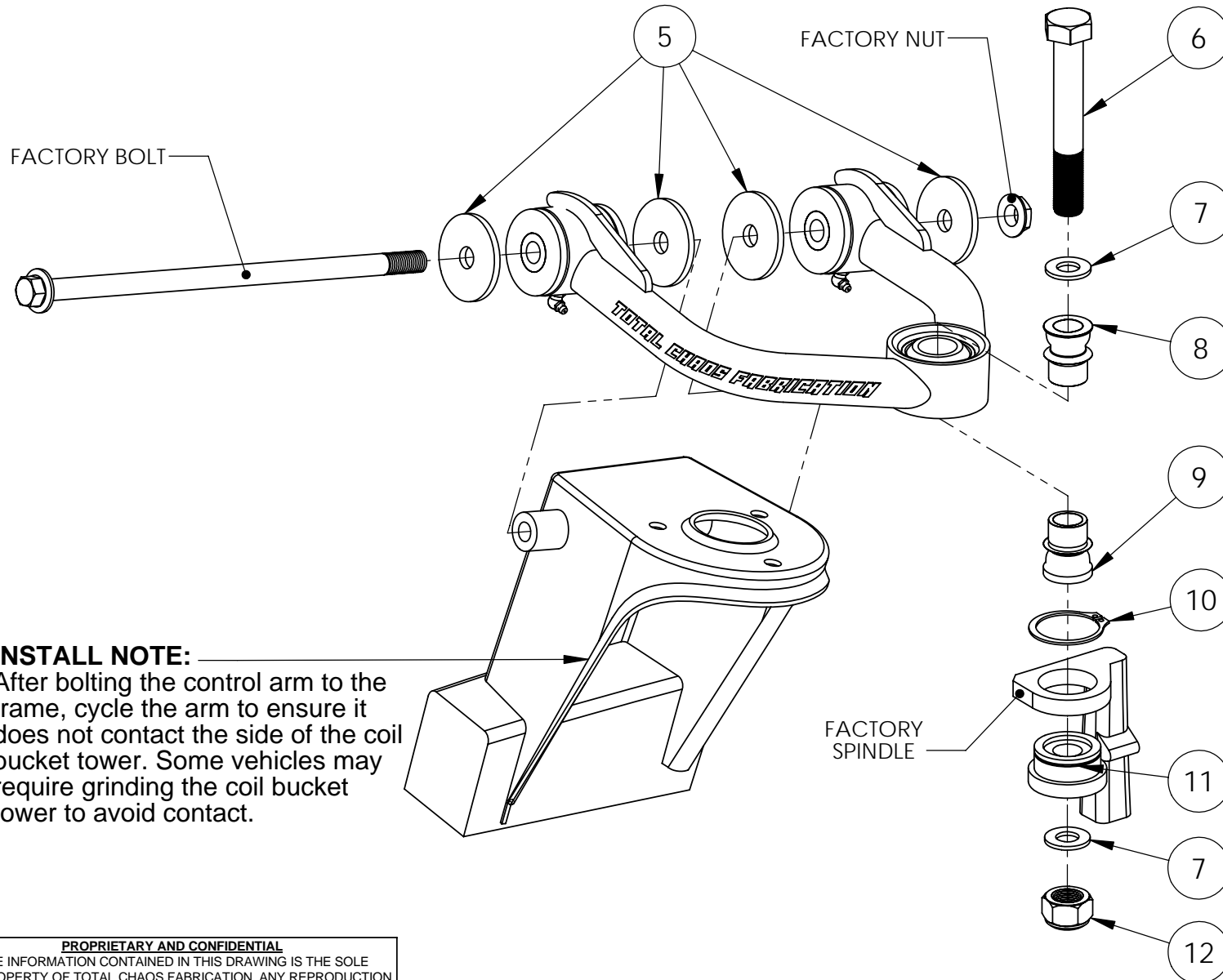

IMPORTANT NOTE:
During assembly, upper & lower spacers are specific. Failure to follow these instructions will result in damage of all components.

Upper spacer is shorter

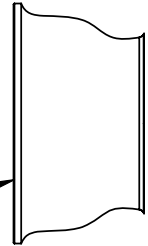

Lower spacer is taller



INSTALL NOTE:

After bolting the control arm to the frame, cycle the arm to ensure it does not contact the side of the coil bucket tower. Some vehicles may require grinding the coil bucket tower to avoid contact.

PROPRIETARY AND CONFIDENTIAL

THE INFORMATION CONTAINED IN THIS DRAWING IS THE SOLE PROPERTY OF TOTAL CHAOS FABRICATION. ANY REPRODUCTION IN PART OR AS A WHOLE WITHOUT THE WRITTEN PERMISSION OF TOTAL CHAOS FABRICATION IS PROHIBITED.

*LEFT SIDE OF TRUCK SHOWN. SOME ITEMS NOT SHOWN FOR CLARITY.

INSTALLATION NOTES

The factory manual is required for torque specifications on all factory hardware. This procedure will involve the removal and re-installation of many parts. Always use factory replacements for worn or damaged parts.

Some items are not shown for clarity.

Page 2

Apply generous amounts of teflon based grease to outside of sleeves and I.D. of urethane bushings. (Teflon based grease is available from TOTAL CHAOS. Part # - Superlube)

Page 3

Torque Item# 6 to 100 ft/lbs.

Inspect all components and re-torque all hardware within 500 miles.

PARTS LIST: 96-04 TACO/TUNDRA/4RUN UPPER CONTROL ARM				
ITEM #	PART #	QTY. PER 96500 KIT	QTY. PER 97500 KIT	ITEM DESCRIPTION
1	99651L	1	0	CONTROL ARM, TACOMA/4RUNNER UPPER LEFT
	99651R	1	0	CONTROL ARM, TACOMA/4RUNNER UPPER RIGHT
	99751L	0	1	CONTROL ARM, TUNDRA/SEQUOIA UPPER LEFT
	99751R	0	1	CONTROL ARM, TUNDRA/SEQUOIA UPPER RIGHT
2	60684	8	8	BUSHING, URETHANE HALF
3	69601	4	0	INNER SLEEVE, TACOMA
	69120	0	4	INNER SLEEVE, TUNDRA
4	10005	4	4	FITTING, GREASE (ZERK)
5	69620	8	8	WASHER, PLATED PIVOT END
6	10350	2	2	BOLT, 3/4" x 5.00L
7	12303	4	4	WASHER, 3/4" AN
8	10034TCF	2	2	SPACER, 3/4" SHORT MISALIGNMENT
9	10034T	2	2	SPACER, 3/4" TALL MISALIGNMENT
10	69615	2	2	SNAP RING, SLUG ADAPTER
11	69616	2	2	BILLET SLUG ADAPATER
12	11302	2	2	NUT, 3/4" C-LOCK

TOTAL CHAOS Fabrication Inc.
159 North Maple St. Unit J
Corona, CA 92880
951.737.9682

PROPRIETARY AND CONFIDENTIAL
THE INFORMATION CONTAINED IN THIS DRAWING IS THE SOLE PROPERTY OF TOTAL CHAOS FABRICATION. ANY REPRODUCTION IN PART OR AS A WHOLE WITHOUT THE WRITTEN PERMISSION OF TOTAL CHAOS FABRICATION IS PROHIBITED.

*LEFT SIDE OF TRUCK SHOWN. SOME ITEMS NOT SHOWN FOR CLARITY.