

INSTALLATION DRAWINGS ARE FOR THE:
2007+ TUNDRA 2WD & 4WD

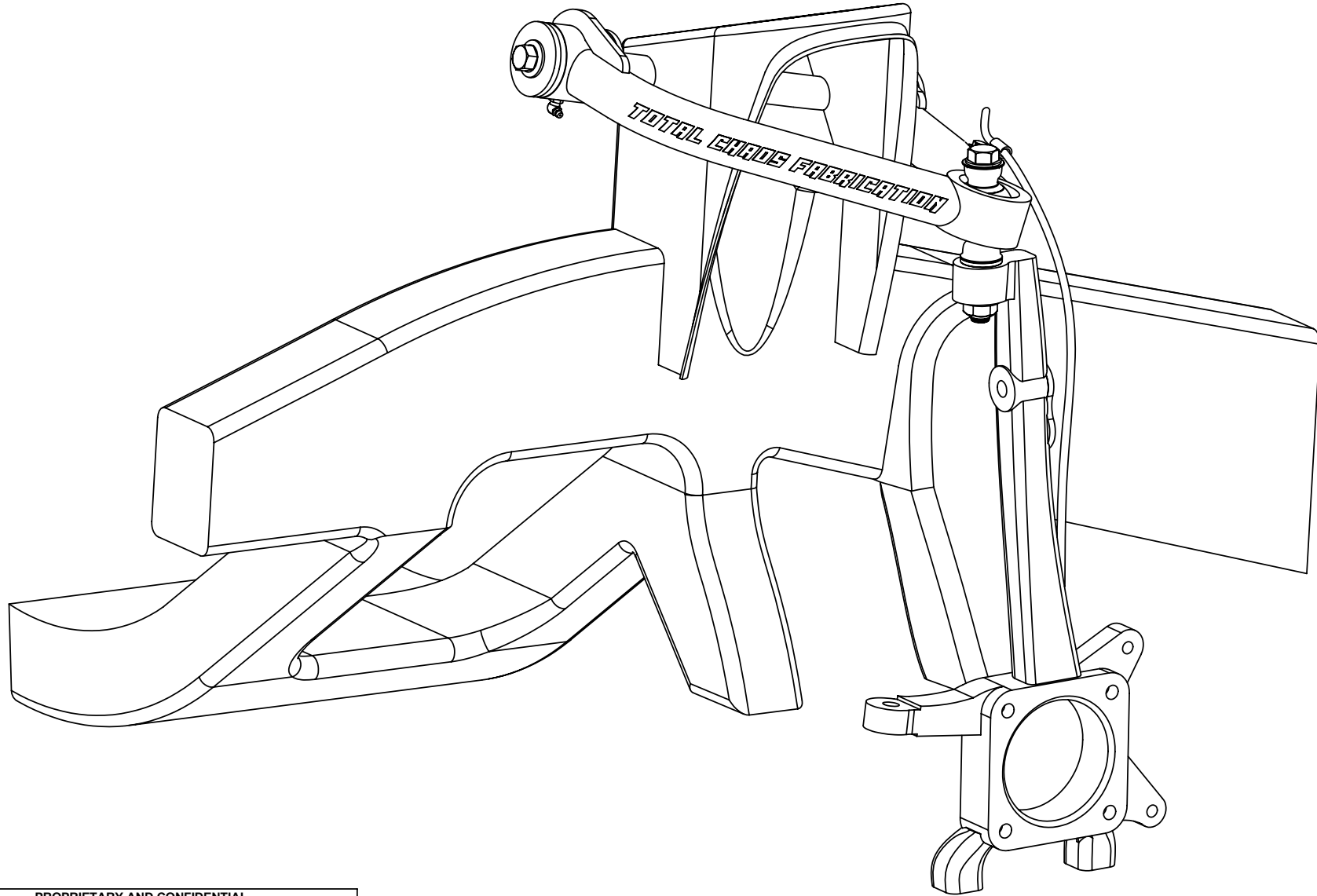

PROPRIETARY AND CONFIDENTIAL

THE INFORMATION CONTAINED IN THIS DRAWING IS THE SOLE PROPERTY OF TOTAL CHAOS FABRICATION. ANY REPRODUCTION IN PART OR AS A WHOLE WITHOUT THE WRITTEN PERMISSION OF TOTAL CHAOS FABRICATION IS PROHIBITED.

*LEFT SIDE OF TRUCK SHOWN. SOME ITEMS NOT SHOWN FOR CLARITY.

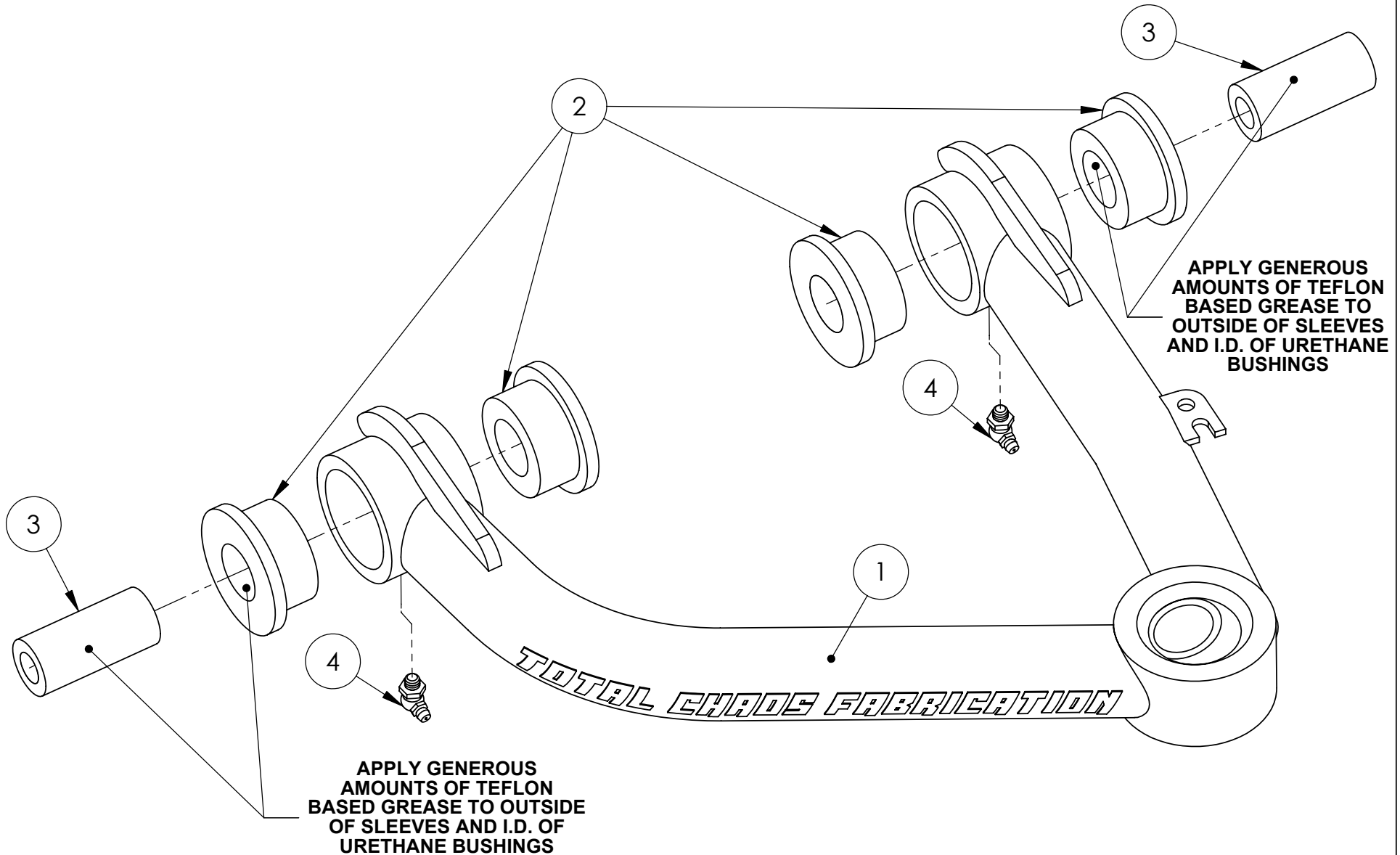

PROPRIETARY AND CONFIDENTIAL

THE INFORMATION CONTAINED IN THIS DRAWING IS THE SOLE PROPERTY OF TOTAL CHAOS FABRICATION. ANY REPRODUCTION IN PART OR AS A WHOLE WITHOUT THE WRITTEN PERMISSION OF TOTAL CHAOS FABRICATION IS PROHIBITED.

*LEFT SIDE OF TRUCK SHOWN. SOME ITEMS NOT SHOWN FOR CLARITY.

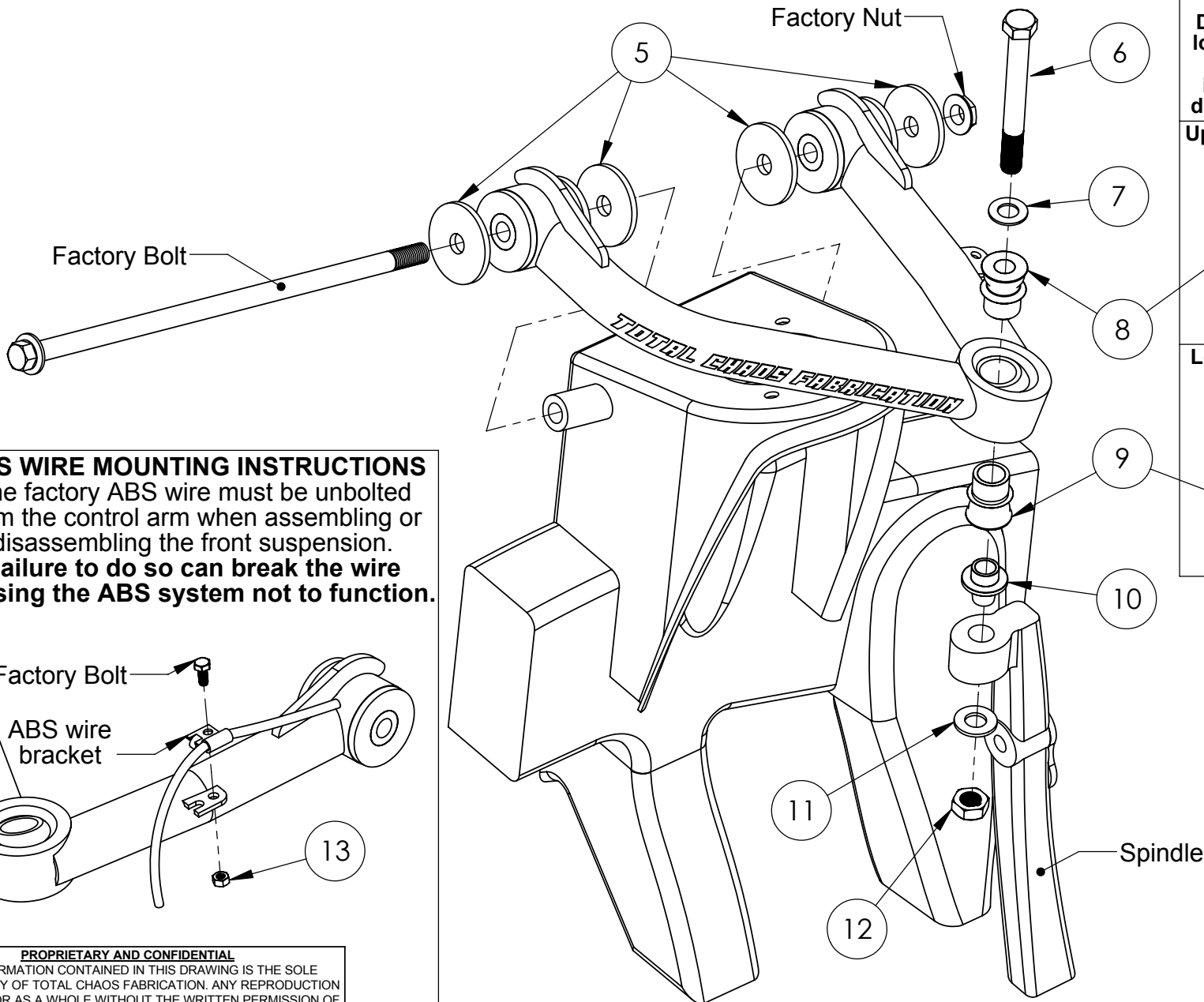

IMPORTANT NOTE:
 During assembly, upper & lower spacers are specific. Failure to follow these instructions will result in damage of all components.

Upper spacer has 9/16" hole

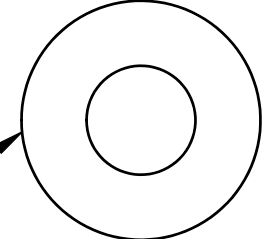

Lower spacer has 3/4" hole

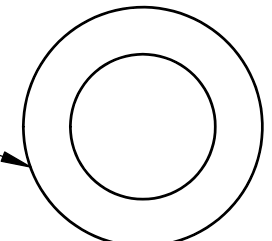

ABS WIRE MOUNTING INSTRUCTIONS

The factory ABS wire must be unbolted from the control arm when assembling or disassembling the front suspension. Failure to do so can break the wire causing the ABS system not to function.

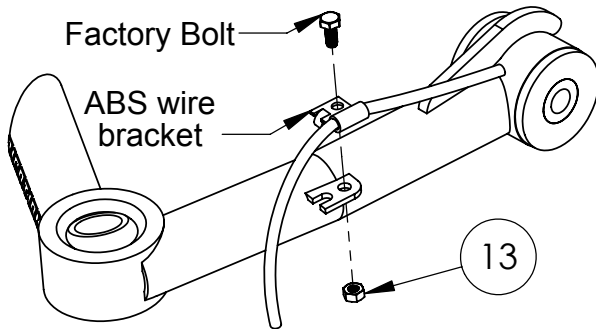

PROPRIETARY AND CONFIDENTIAL
 THE INFORMATION CONTAINED IN THIS DRAWING IS THE SOLE PROPERTY OF TOTAL CHAOS FABRICATION. ANY REPRODUCTION IN PART OR AS A WHOLE WITHOUT THE WRITTEN PERMISSION OF TOTAL CHAOS FABRICATION IS PROHIBITED.

*LEFT SIDE OF TRUCK SHOWN. SOME ITEMS NOT SHOWN FOR CLARITY.

INSTALLATION NOTES

The factory manual is required for torque specifications on all factory hardware. This procedure will involve the removal and re-installation of many parts. Always use factory replacements for worn or damaged parts.

Some items are not shown for clarity.

Page 2
Apply generous amounts of teflon based grease to outside of sleeves and I.D. of urethane bushings. (Teflon based grease is available from TOTAL CHAOS. Part # - Superlube)

Page 3
Torque Item# 6 to 100 ft/lbs.

Inspect all components and re-torque all hardware within 500 miles.

PARTS LIST: 07+ TUNDRA UPPER CONTROL ARM			
ITEM #	PART #	QTY.	ITEM DESCRIPTION
1	87501L	1	CONTROL ARM, 07+ TUNDRA UPPER LEFT
	87501R	1	CONTROL ARM, 07+ TUNDRA UPPER RIGHT
2	60684	8	BUSHING, URETHANE HALF
3	69707	4	INNER SLEEVE
4	10005	4	FITTING, GREASE (ZERK)
5	69720	8	WASHER, PLATED PIVOT END
6	10251	2	BOLT, 9/16" x 5.00L
7	12203	2	WASHER, 9/16" AN
8	100916	2	SPACER, 9/16" MISALIGNMENT
9	10034TCF	2	SPACER, 3/4" MISALIGNMENT
10	30005	2	SLEEVE, 9/16" TAPERED ADAPTER
11	12204	2	WASHER, 9/16" SAE
12	11202	2	NUT, 9/16" C-LOCK
13	11061	2	NUT, 6m m ABS BRACKET

INSTALL NOTE:

After bolting the control arm to the frame, cycle the arm to ensure it does not contact the side of the coil bucket tower. Some vehicles may require grinding the coil bucket tower to avoid contact.

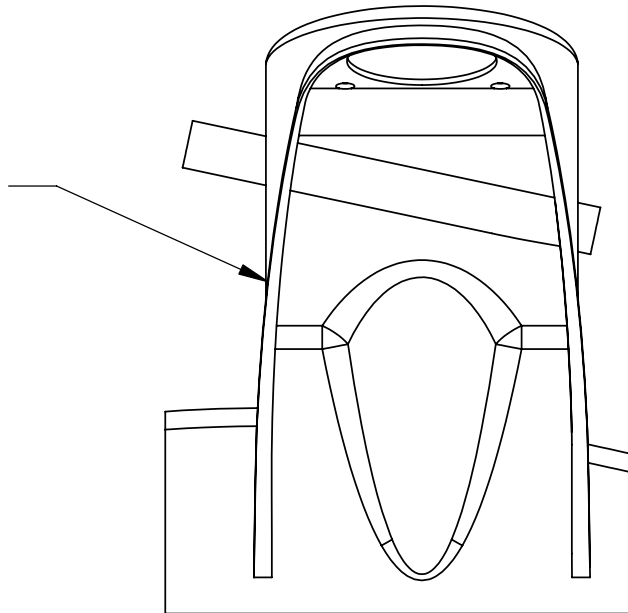

TOTAL CHAOS Fabrication Inc.
159 North Maple St. Unit J
Corona, CA 92880
951.737.9682

PROPRIETARY AND CONFIDENTIAL
THE INFORMATION CONTAINED IN THIS DRAWING IS THE SOLE PROPERTY OF TOTAL CHAOS FABRICATION. ANY REPRODUCTION IN PART OR AS A WHOLE WITHOUT THE WRITTEN PERMISSION OF TOTAL CHAOS FABRICATION IS PROHIBITED.

*LEFT SIDE OF TRUCK SHOWN. SOME ITEMS NOT SHOWN FOR CLARITY.