

**TOTAL CHAOS  
FABRICATION**

www.chaosfab.com

# INSTALLATION INSTRUCTIONS

05+ TACOMA PRERUNNER/4WD U.C.A.  
03+ 4RUNNER/07+ FJ CRUISER U.C.A.

**TC-96504**

DATE: 5/9/2007  
REV.: 02  
SCALE: N.T.S.  
PAGE: 1 OF 4  
DRAWN: SW

INSTALLATION DRAWINGS ARE FOR THE:  
2005+ TACOMA PRERUNNER & 4WD  
2003+ 4RUNNER 2WD/4WD  
2007+ FJ CRUISER

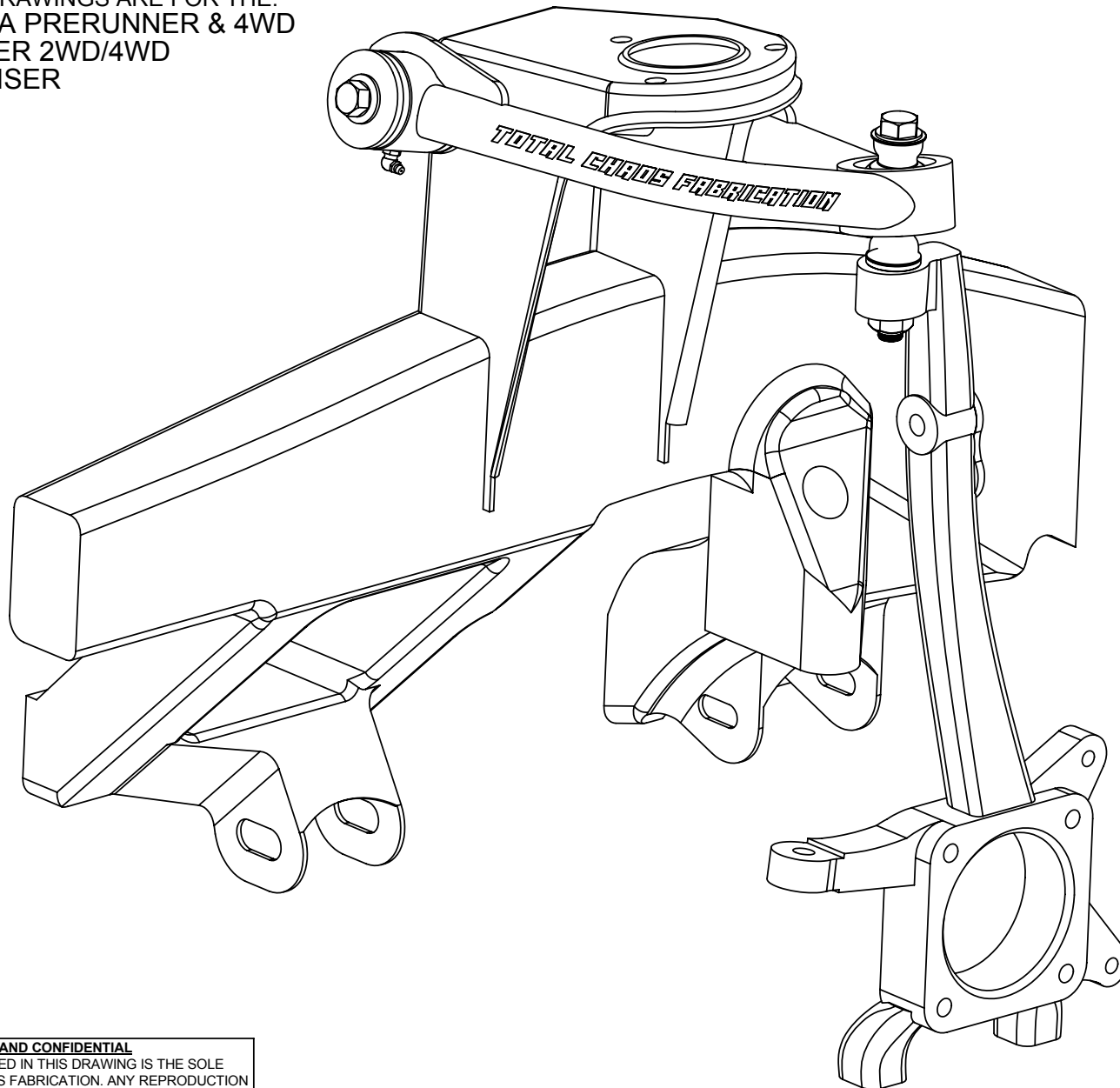

**PROPRIETARY AND CONFIDENTIAL**

THE INFORMATION CONTAINED IN THIS DRAWING IS THE SOLE PROPERTY OF TOTAL CHAOS FABRICATION. ANY REPRODUCTION IN PART OR AS A WHOLE WITHOUT THE WRITTEN PERMISSION OF TOTAL CHAOS FABRICATION IS PROHIBITED.

\*LEFT SIDE OF TRUCK SHOWN. SOME ITEMS NOT SHOWN FOR CLARITY.

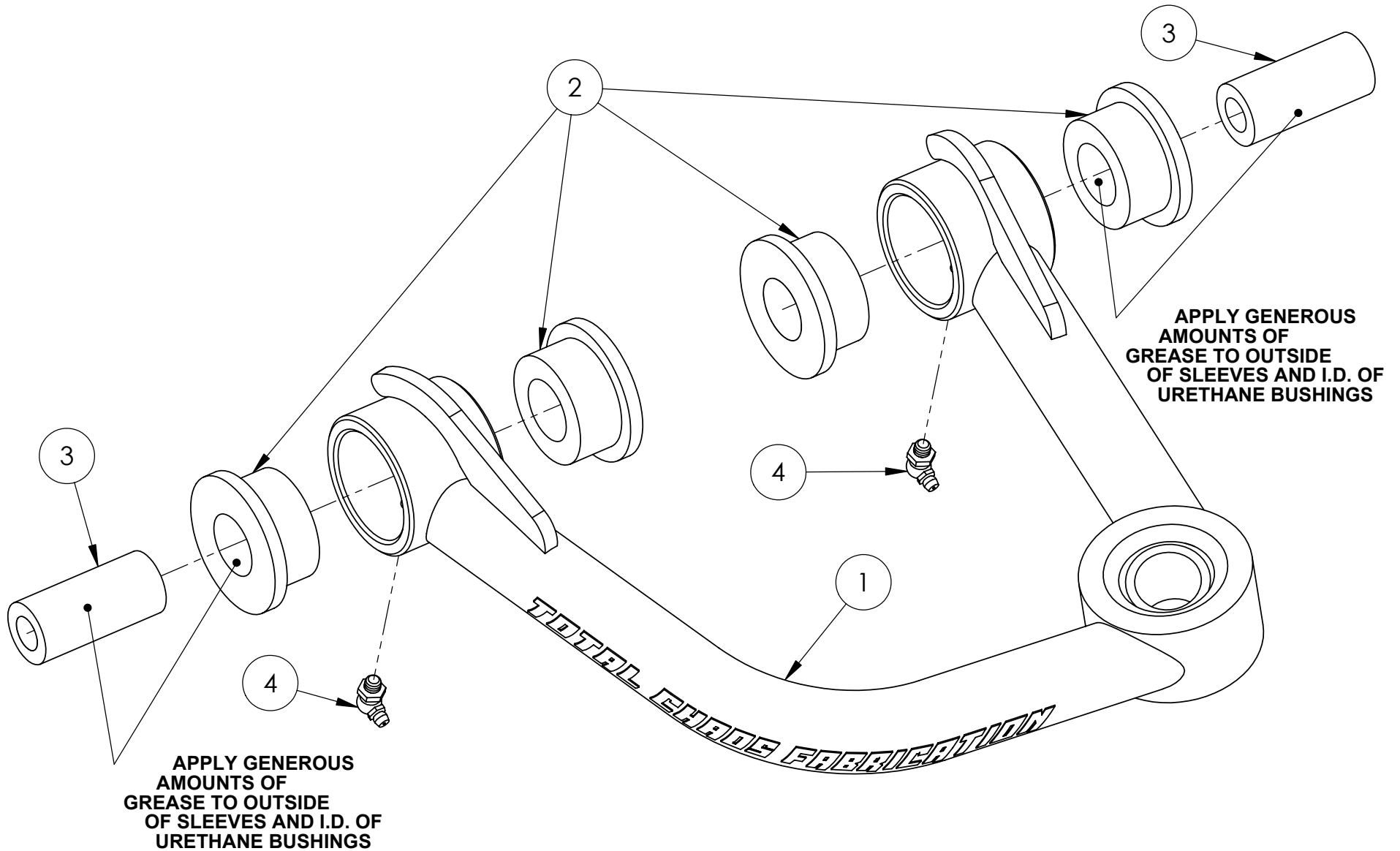

**PROPRIETARY AND CONFIDENTIAL**  
THE INFORMATION CONTAINED IN THIS DRAWING IS THE SOLE PROPERTY OF TOTAL CHAOS FABRICATION. ANY REPRODUCTION IN PART OR AS A WHOLE WITHOUT THE WRITTEN PERMISSION OF TOTAL CHAOS FABRICATION IS PROHIBITED.

\*LEFT SIDE OF TRUCK SHOWN. SOME ITEMS NOT SHOWN FOR CLARITY.

**Important Note:**

When removing the factory upper control arm bolt, you will need to bend the inner fender well on both sides of the truck. Once installation is complete, bend it back to its original position.

**IMPORTANT NOTE:**  
 During assembly, upper & lower spacers are specific. Failure to follow these instructions will result in damage of all components.

Upper spacer has 9/16" hole

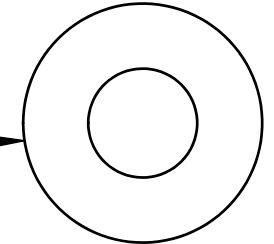

Lower spacer has 3/4" hole

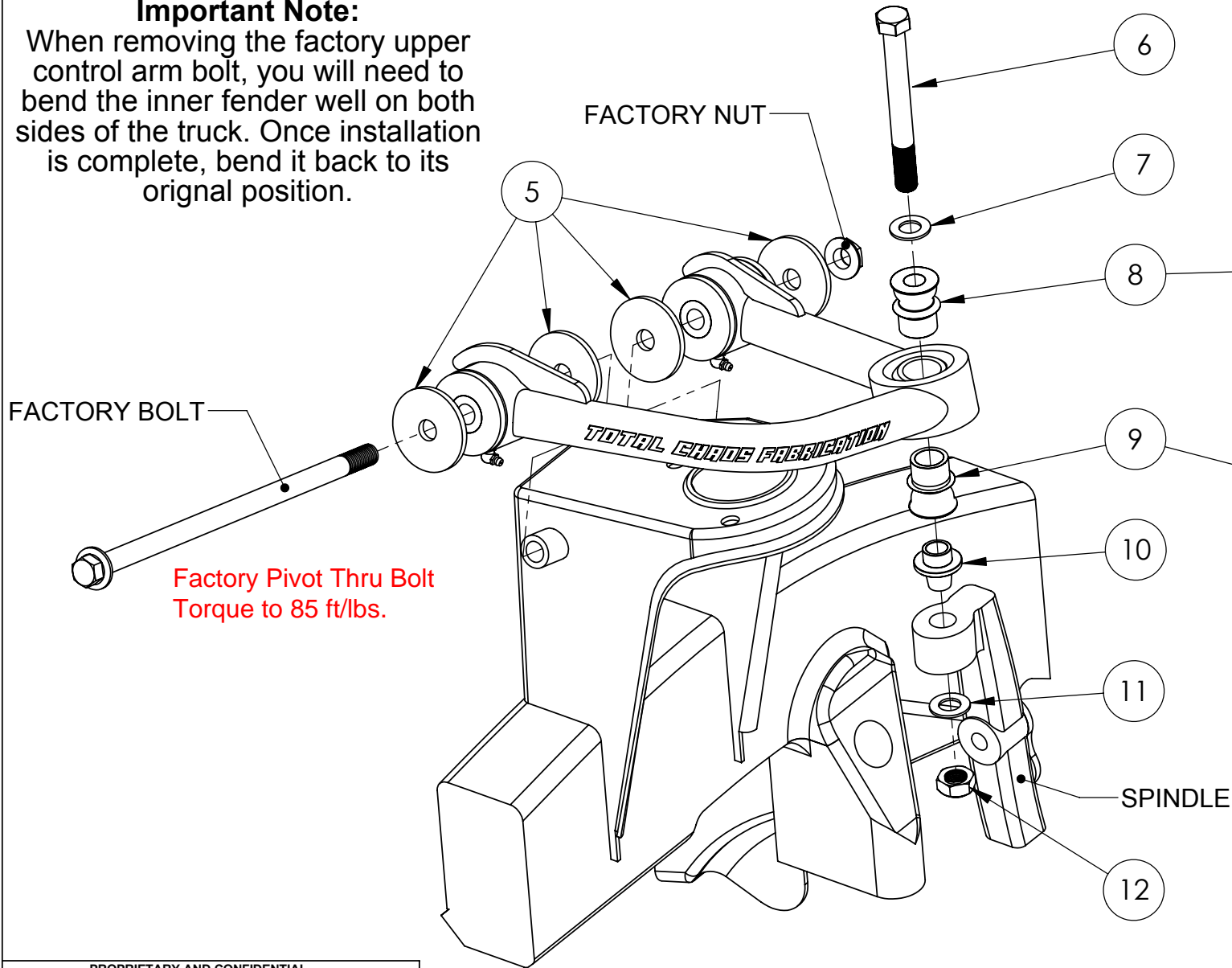
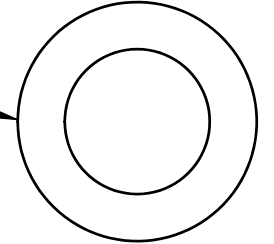

**PROPRIETARY AND CONFIDENTIAL**  
 THE INFORMATION CONTAINED IN THIS DRAWING IS THE SOLE PROPERTY OF TOTAL CHAOS FABRICATION. ANY REPRODUCTION IN PART OR AS A WHOLE WITHOUT THE WRITTEN PERMISSION OF TOTAL CHAOS FABRICATION IS PROHIBITED.

\*LEFT SIDE OF TRUCK SHOWN. SOME ITEMS NOT SHOWN FOR CLARITY.

**INSTALLATION NOTES**

The factory manual is required for torque specifications on all factory hardware. This procedure will involve the removal and re-installation of many parts. Always use factory replacements for worn or damaged parts.

Some items are not shown for clarity.

Page 2  
Apply generous amounts of grease to outside of sleeves and I.D. of urethane bushings.

Page 3  
Torque Item# 6 to 100 ft/lbs.

Inspect all components and re-torque all hardware within 500 miles.

PARTS LIST: 05+ TACO/FJ/4RUN UPPER CONTROL ARM			
ITEM #	PART #	QTY.	ITEM DESCRIPTION
1	99654L	1	CONTROL ARM, 05+ TACOMA UPPER LEFT
	99654R	1	CONTROL ARM, 05+ TACOMA UPPER RIGHT
2	60684	8	BUSHING, URETHANE HALF
3	69120	4	INNER SLEEVE
4	10005	4	FITTING, GREASE (ZERK)
5	69620	8	WASHER, PLATED PIVOT END
6	10251	2	BOLT, 9/16" x 5.00L
7	12203	2	WASHER, 9/16" AN
8	100916	2	SPACER, 9/16" MISALIGNMENT
9	10034TCF	2	SPACER, 3/4" MISALIGNMENT
10	30004	2	SLEEVE, 9/16" TAPERED ADAPTER
11	12204	2	WASHER, 9/16" SAE
12	11202	2	NUT, 9/16" C-LOCK

**TOTAL CHAOS Fabrication Inc.**  
159 North Maple St. Unit J  
Corona, CA 92880  
951.737.9682

**PROPRIETARY AND CONFIDENTIAL**  
THE INFORMATION CONTAINED IN THIS DRAWING IS THE SOLE PROPERTY OF TOTAL CHAOS FABRICATION. ANY REPRODUCTION IN PART OR AS A WHOLE WITHOUT THE WRITTEN PERMISSION OF TOTAL CHAOS FABRICATION IS PROHIBITED.

\*LEFT SIDE OF TRUCK SHOWN. SOME ITEMS NOT SHOWN FOR CLARITY.