

INSTALLATION DRAWINGS ARE FOR THE FOLLOWING:  
1995.5-2004 TACOMA PRERUNNER & 4WD  
1996-2002 4RUNNER 2WD/4WD

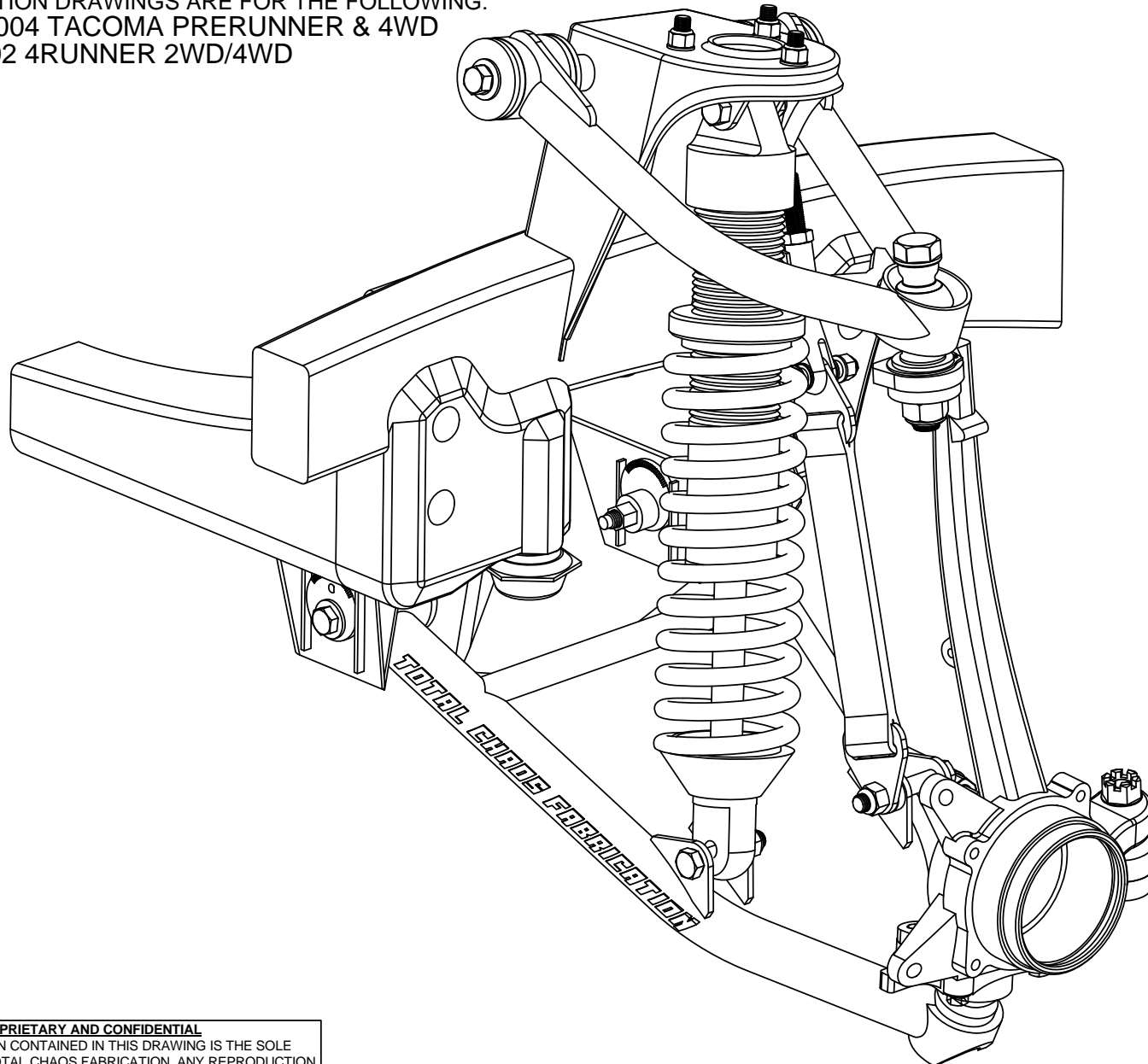

**PROPRIETARY AND CONFIDENTIAL**

THE INFORMATION CONTAINED IN THIS DRAWING IS THE SOLE PROPERTY OF TOTAL CHAOS FABRICATION. ANY REPRODUCTION IN PART OR AS A WHOLE WITHOUT THE WRITTEN PERMISSION OF TOTAL CHAOS FABRICATION IS PROHIBITED.

\*LEFT SIDE OF TRUCK SHOWN. SOME ITEMS NOT SHOWN FOR CLARITY.

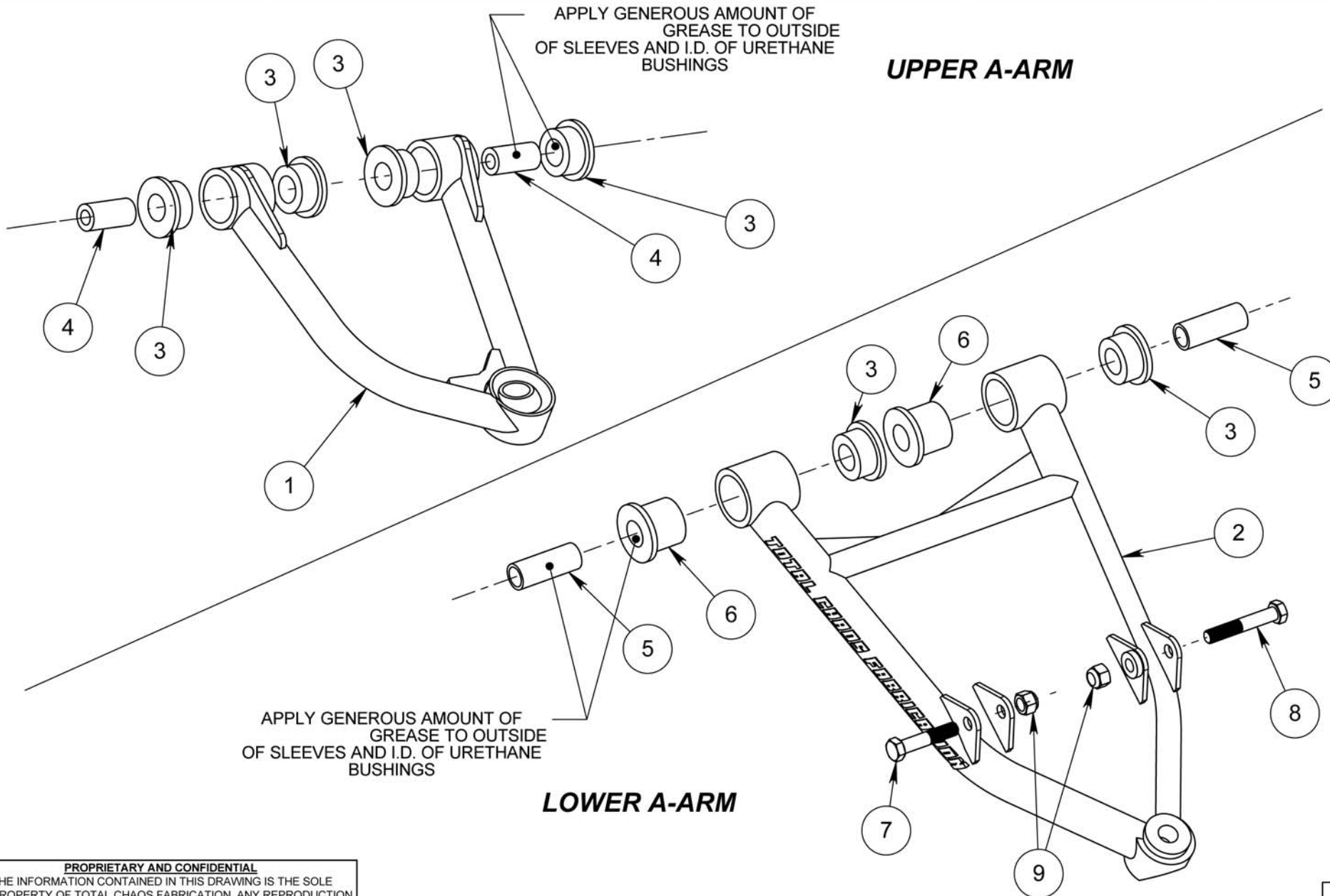

**PROPRIETARY AND CONFIDENTIAL**  
 THE INFORMATION CONTAINED IN THIS DRAWING IS THE SOLE PROPERTY OF TOTAL CHAOS FABRICATION. ANY REPRODUCTION IN PART OR AS A WHOLE WITHOUT THE WRITTEN PERMISSION OF TOTAL CHAOS FABRICATION IS PROHIBITED.

\*LEFT SIDE OF TRUCK SHOWN. SOME ITEMS NOT SHOWN FOR CLARITY.

**UPPER A-ARM / SHOCK BRACKET**

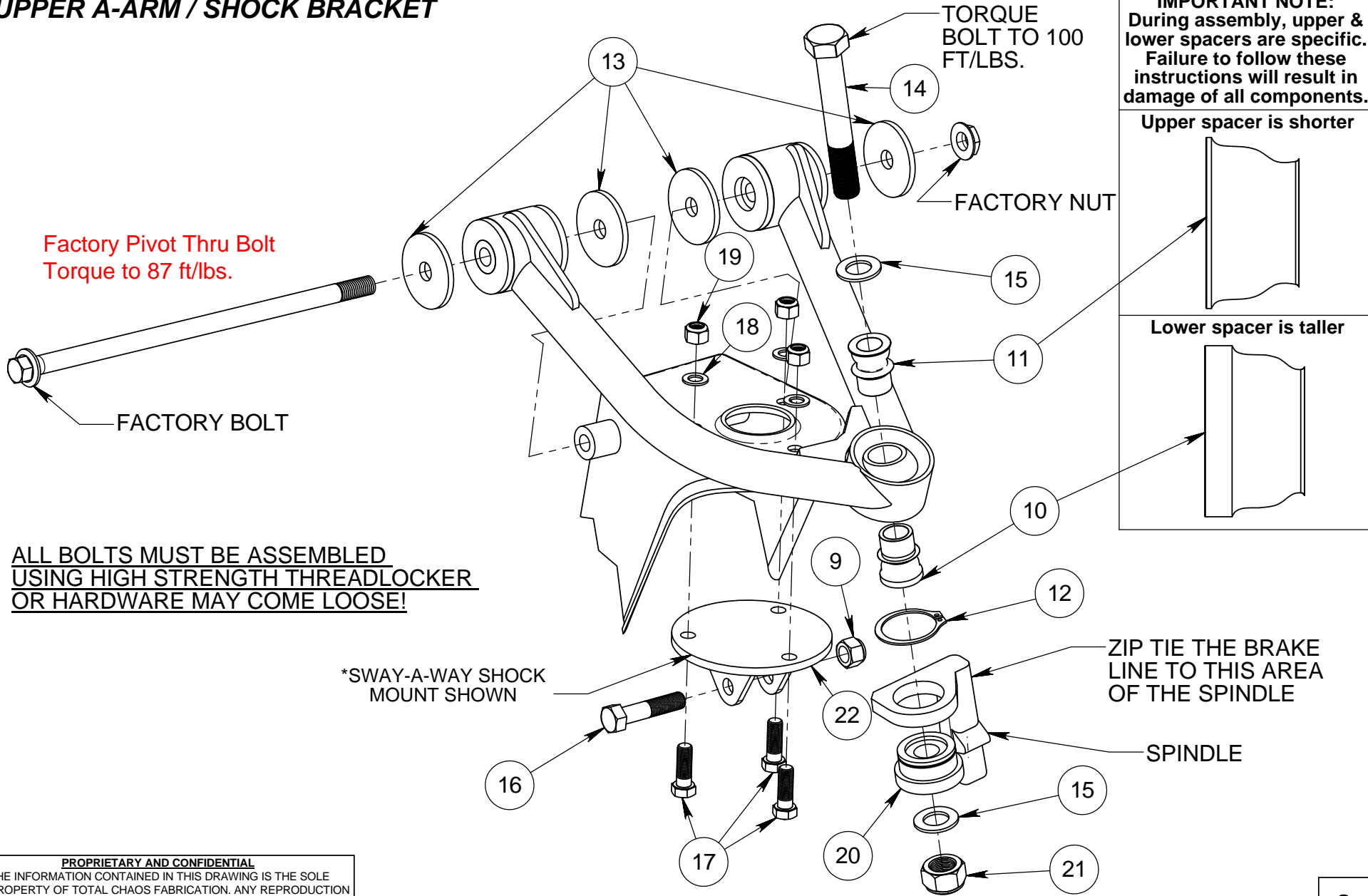

**ALL BOLTS MUST BE ASSEMBLED USING HIGH STRENGTH THREADLOCKER OR HARDWARE MAY COME LOOSE!**

**PROPRIETARY AND CONFIDENTIAL**  
 THE INFORMATION CONTAINED IN THIS DRAWING IS THE SOLE PROPERTY OF TOTAL CHAOS FABRICATION. ANY REPRODUCTION IN PART OR AS A WHOLE WITHOUT THE WRITTEN PERMISSION OF TOTAL CHAOS FABRICATION IS PROHIBITED.

**\*LEFT SIDE OF TRUCK SHOWN. SOME ITEMS NOT SHOWN FOR CLARITY.**

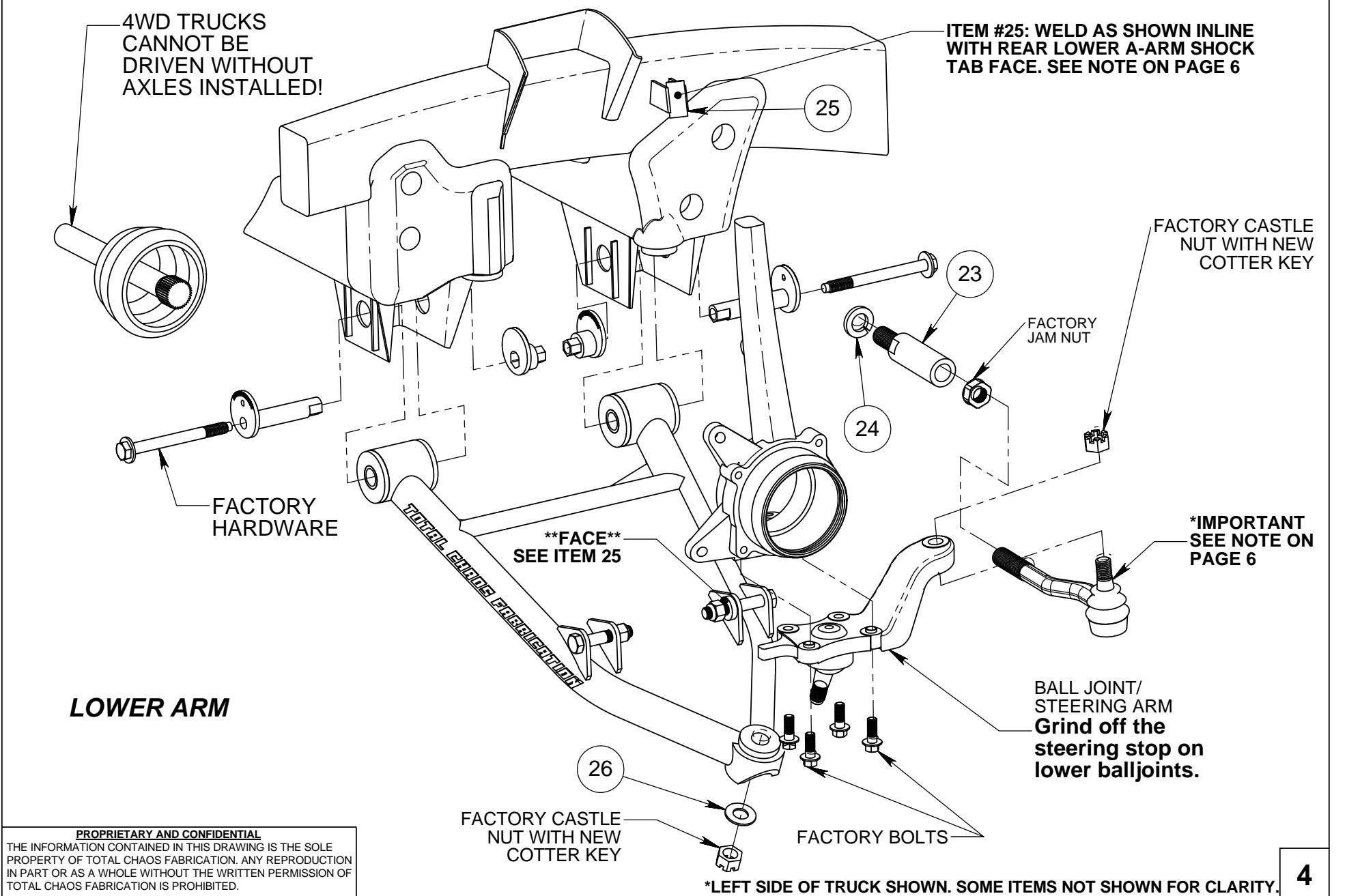

**BUMP STOP & LIMIT STRAP**

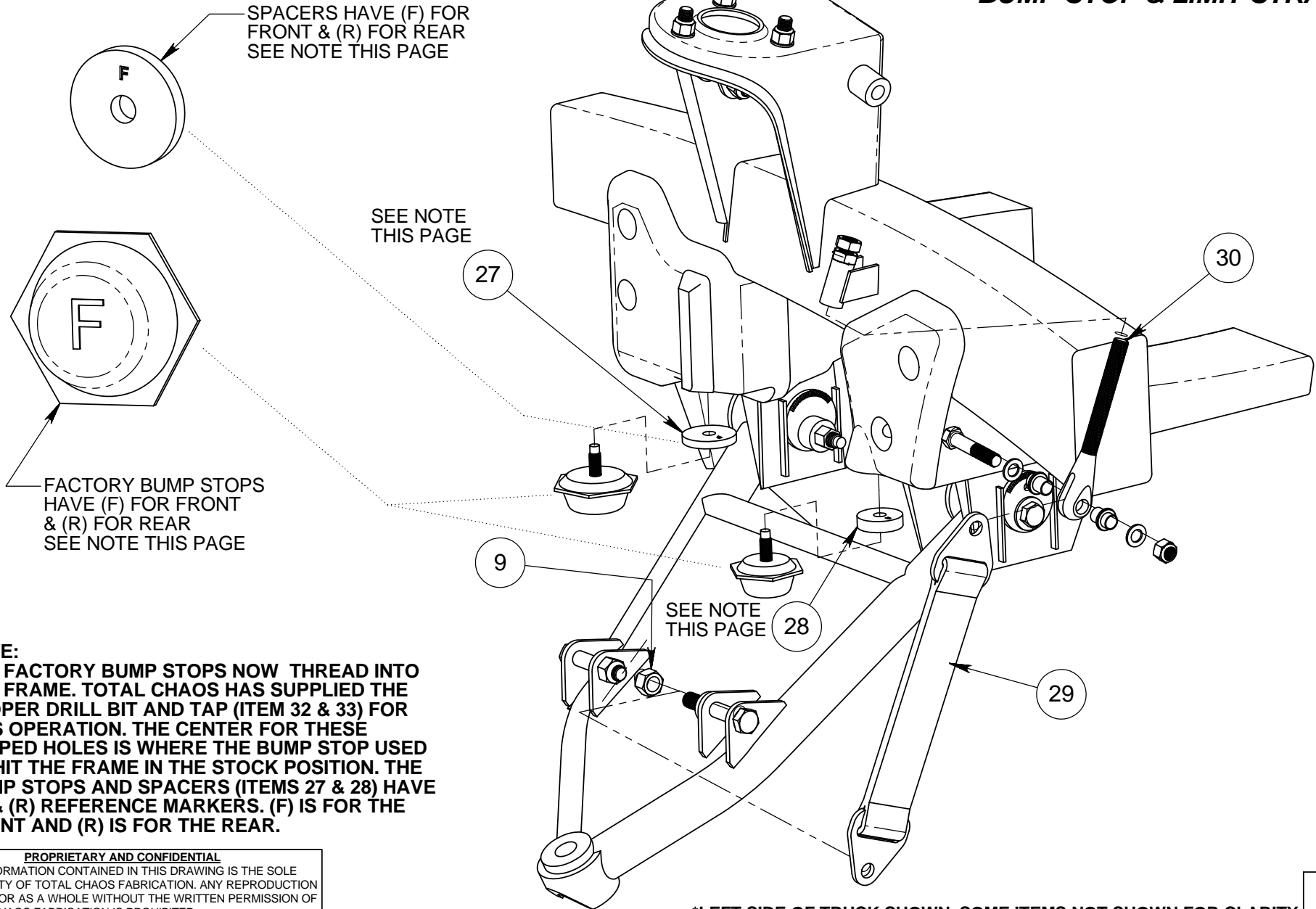

SPACERS HAVE (F) FOR FRONT & (R) FOR REAR SEE NOTE THIS PAGE

SEE NOTE THIS PAGE

FACTORY BUMP STOPS HAVE (F) FOR FRONT & (R) FOR REAR SEE NOTE THIS PAGE

SEE NOTE THIS PAGE

**NOTE:**  
 THE FACTORY BUMP STOPS NOW THREAD INTO THE FRAME. TOTAL CHAOS HAS SUPPLIED THE PROPER DRILL BIT AND TAP (ITEM 32 & 33) FOR THIS OPERATION. THE CENTER FOR THESE TAPPED HOLES IS WHERE THE BUMP STOP USED TO HIT THE FRAME IN THE STOCK POSITION. THE BUMP STOPS AND SPACERS (ITEMS 27 & 28) HAVE (F) & (R) REFERENCE MARKERS. (F) IS FOR THE FRONT AND (R) IS FOR THE REAR.

**PROPRIETARY AND CONFIDENTIAL**

THE INFORMATION CONTAINED IN THIS DRAWING IS THE SOLE PROPERTY OF TOTAL CHAOS FABRICATION. ANY REPRODUCTION IN PART OR AS A WHOLE WITHOUT THE WRITTEN PERMISSION OF TOTAL CHAOS FABRICATION IS PROHIBITED.

\*LEFT SIDE OF TRUCK SHOWN. SOME ITEMS NOT SHOWN FOR CLARITY.

**INSTALLATION NOTES**

The factory manual is required for torque specifications on all hardware. This procedure will involve the removal and re-installation of many parts. Always use replacement factory parts for any worn or damaged parts. Always use new cotter keys for reinstallation.

Some items are not shown for clarity.

**Page 2**

Apply generous amounts of grease on items 4 & 5.

**Page 3**

(Tacoma Truck ONLY, Not 4Runner) Item 35, brake line needs to be attached with a cable tie on the inboard side of the spindle.

**Page 4**

(Tacoma Truck ONLY, Not 4Runner) Tacoma tierod ends are switched from right to left and left to right. Use the right tierod on the left side of truck. Item 25, Weld bracket as shown. Grind frame to bare metal and weld.

**Page 5**

After installation is complete (shocks installed), adjust limit strap so that there is a 1/4" gap between the high misalignment spacer and the uniball cup on the upper control arm (see model below). Limit straps will stretch over time and will need to be adjusted periodically to prevent damage to shocks and uniball components.

**\*\*\*IMPORTANT INFORMATION\*\*\***

**1. 4WD TRUCKS CANNOT BE DRIVEN WITHOUT AXLES INSTALLED!** Wheel bearings will fail causing serious damage and/or injury.

**2. Grind off the steering stops on lower balljoints. Steering stops will contact the lower control arms and cause damage to the arms.**

Inspect all components and re-torque all hardware within 500 miles.

Total Chaos Fabrication Inc  
159 North Maple St. Unit J  
Corona, CA 92880  
951.737.9682

WWW.CHAOSFAB.COM

**PROPRIETARY AND CONFIDENTIAL**  
THE INFORMATION CONTAINED IN THIS DRAWING IS THE SOLE PROPERTY OF TOTAL CHAOS FABRICATION. ANY REPRODUCTION IN PART OR AS A WHOLE WITHOUT THE WRITTEN PERMISSION OF TOTAL CHAOS FABRICATION IS PROHIBITED.

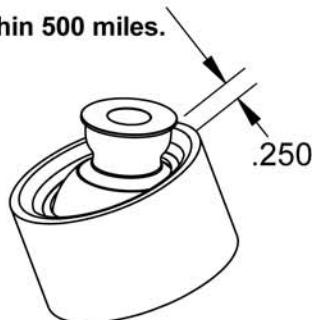

**PARTS LIST: 95.5-04 TOYOTA TACOMA/4RUNNER LONG TRAVEL KIT**

ITEM #	PART #	QTY. (PER KIT)	ITEM DESCRIPTION
1	99601R	1	CONTROL ARM, UPPER RIGHT
	99601L	1	CONTROL ARM, UPPER LEFT
2	99602R	1	CONTROL ARM, LOWER RIGHT
	99602L	1	CONTROL ARM, LOWER LEFT
3	60684	12	BUSHING, URETHANE HALF
4	69601	4	INNER SLEEVE, UPPER CONTROL ARM
5	69602	4	INNER SLEEVE, LOWER CONTROL ARM
6	60292	4	BUSHING, URETHANE HALF
7	10025	2	BOLT, 1/2" x 2.50L
8	10030	2	BOLT, 1/2" x 3.00L
9	11001	6	NUT, 1/2" NYLOCK
10	10034T	2	SPACER, 3/4" MISALIGNMENT, TALL
11	10034TCF	2	SPACER, 3/4" MISALIGNMENT, SHORT
12	69615	2	RETAINING CLIP, SLUG ADAPTER
13	69620	8	END WASHER, UPPER CONTROL ARM
14	10350	2	BOLT, 3/4" x 5.00L UNIBALL TO SPINDLE
15	12303	4	WASHER, 3/4" AN
16	10025	2	BOLT, 1/2" x 2.50L SAW SHOCK
	10045	2	BOLT, 1/2" X 4.25L FOX/KING SHOCK
17	10515	6	BOLT, 7/16" x 1.50L
18	12504	6	WASHER, 7/16" SAE
19	11501	6	NUT, 7/16" NYLOCK
20	69616	2	ADAPTER, UNIBALL SLUG
21	11302	2	NUT, 3/4" C-LOCK
22	59721K	2	SHOCK CIRCLE, FOX/KING TACO & 4RUNNER
	59620S	2	SHOCK CIRCLE, SWAY A WAY, TACO
	59720S	2	SHOCK CIRCLE, SWAY A WAY, 4RUNNER
23	99020	2	EXTENSION, STEERING
24	12020	2	WASHER, STEERING EXTENSION LOCK
25	69619	2	BRACKET, LIMIT STRAP ADJUSTER, WELD ON
26	12104	2	WASHER, 5/8" SAE
27	69610	2	SPACER, TACO FRONT BUMPSTOP
28	69612	2	SPACER, TACO REAR BUMPSTOP
29	69617	2	STRAP, 12" LIMIT
30	69618	2	CLEVIS, LIMIT STRAP ADJUSTER
31	96330	1	KIT, EXTENDED BRAKELINE, TACO
	97330	1	KIT, EXTENDED BRAKELINE, 4RUNNER
32	69613	1	DRILL BIT, 5/16"
33	69614	1	TAP, HAND
	59204	4	RESERVOIR MOUNT, WELD-ON SHOCK

\*LEFT SIDE OF TRUCK SHOWN. SOME ITEMS NOT SHOWN FOR CLARITY.